

MINNESOTA DEPARTMENT OF TRANSPORTATION
LINCOLN COUNTY

CONSTRUCTION PLAN FOR REPLACEMENT OF BRIDGE NO. L2098 WITH 1 LINE OF 14'X6' R.C. BOX CULVERT

LOCATED ON 270TH ST. BETWEEN INTERSECTION OF 160TH AVE. AND CR. 104 IN SHAOKATAN TOWNSHIP (Geographic description)

FROM NORTHEAST CORNER SEC. 11-T111N-R46W TO NORTHEAST CORNER OF SEC. 12-T111N-R46W (Legal description)

PLANS SYMBOLS

- STATE LINE
- COUNTY LINE
- TOWNSHIP OR RANGE LINE
- SECTION LINE
- QUARTER LINE
- PRESENT ROW
- NEW ROW
- TEMPORARY EASEMENT
- CONTROL OF ACCESS LINE
- PROPERTY LINES
- VACATED PLATTED PROPERTY
- CORPORATE OR CITY LIMITS
- RETAINING WALL
- RAILROAD
- RAILROAD RIGHT-OF-WAY
- DRAINAGE DITCH
- DRAIN TILE
- CULVERT
- DROP INLET
- GUARD RAIL
- BARBED WIRE FENCE
- WOVEN WIRE FENCE
- CHAIN LINK FENCE
- RAILROAD SNOW FENCE
- SWAMP
- TIMBER
- ORCHARD
- BRUSH
- NURSERY
- CATCH BASIN
- FIRE HYDRANT
- BUILDING (ONE STORY FRAME)
- F - FRAME C - CONCRETE
- S - STONE T - TILE
- B - BRICK ST - STUCCO
- IRON PIPE OR ROD
- MONUMENT (STONE, CONC. OR METAL)
- WOODEN HUB
- GRAVEL PIT
- SAND PIT
- BORROW PIT
- ROCK QUARRY

UTILITIES SYMBOLS

- POWER POLE LINE
- TELEPHONE LINE
- JOINT TELEPHONE AND POWER LINE
- ANCHOR
- STEEL TOWER
- STREET LIGHT
- PEDESTAL (TELEPHONE CABLE TERMINAL)
- GAS MAIN
- WATER MAIN
- CONDUIT
- TELEPHONE CABLE IN CONDUIT
- ELECTRIC CABLE IN CONDUIT
- TELEPHONE MANHOLE
- ELECTRIC MANHOLE
- BURIED TELEPHONE CABLE
- BURIED POWER CABLE
- SEWER (SANITARY OR STORM)
- SEWER MANHOLE
- POWER POLE



SCALE: 1 MILE

FEDERAL PROJECT NO. _____

SPECIFICATIONS

THE 2020 EDITION OF THE MINNESOTA DEPARTMENT OF TRANSPORTATION "STANDARD SPECIFICATIONS FOR CONSTRUCTION" AND THE "SUPPLEMENTAL SPECIFICATIONS" DATED SEPTEMBER 2022 SHALL GOVERN.

INDEX

- 1.) TITLE SHEET
- 2.) ESTIMATED QUANTITIES
- 3.) GENERAL PLAN AND ELEVATION
- 4.) STAKEOUT
- 5-6.) BARREL & END SECTION DETAILS
- 7.) EMBANKMENT PROTECTION
- 8.) EROSION & SEDIMENT CONTROL PLAN
- 9.) EROSION & SEDIMENT CONTROL DETAILS
- 10.) PLAN & PROFILE
- 11.) BRIDGE SURVEY SHEET
- 12.) SWPPP
- 13.) TRAFFIC CONTROL

THIS PLAN CONTAINS 13 SHEETS

DESIGN DESIGNATION

R-VALUE _____
 ADT (2022) LESS THAN 50
 Proj. ADT (2042) LESS THAN 50
 Proj. HCADT (2042) _____
 Soil Factor _____
 Shoulder Width 1 FT.

OR

FUNCTIONAL CLASSIFICATION LOCAL
 NO. OF TRAFFIC LANES 2 NO. OF PARKING LANES 0
 DESIGN SPEED 30 MPH
 BASED ON STOPPING SIGHT DISTANCE
 HEIGHT OF EYE 3.5 FT. HEIGHT OF OBJECT 2.0 FT.
 DESIGN SPEED NOT ACHIEVED AT: N/A
 STA. _____ TO STA. _____

LOCAL AGENCY SIGNATURES

Signature: Joseph M. Wilson Typed or Printed Name: Joseph M. Wilson
 Design Engineer: I hereby certify that this plan was prepared by me or under my direct supervision, and that I am a duly Licensed Professional Engineer under the laws of the State of Minnesota.

Date: 1-4-23

License Number 54947

Approved: Joseph M. Wilson Date: 1-4-23
 Lincoln County Engineer

District State-Aid Engineer: _____ Date: _____
 Reviewed for Compliance with State-Aid Rules/Policy

State-Aid Engineer: _____ Date: _____
 Approved for State Aid Funding

ESTIMATED QUANTITIES

NOTES	ITEM NO.	ITEM	UNITS	TOTAL PARTICIPATING	TOTAL NON-PARTICIPATING	TOTAL ESTIMATED QUANTITIES
	2021.501	MOBILIZATION	LUMP SUM	1		1
1	2118.509	AGGREGATE SURFACING CLASS 1	TON		162	162
2	2412.502	14X6 PRECAST CONCRETE BOX CULVERT END SECTION	EACH	2		2
3.4	2412.503	14X6 PRECAST CONCRETE BOX CULVERT	LIN FT	42		42
5.6	2442.501	REMOVE EXISTING BRIDGE	LUMP SUM		1	1
7	2451.507	COARSE FILTER AGGREGATE (CV) (P)	CU YD	156		156
8	2451.609	GRANULAR BACKFILL	TON	150		150
9	2502.503	6" PERF PE PIPE DRAIN	LIN FT		20	20
10	2502.602	DRAIN OUTLET DESIGN SPECIAL	EACH		1	1
11.12	2511.509	RANDOM RIPRAP CLASS III	TON	144		144
	2563.601	TRAFFIC CONTROL	LUMP SUM	1		1
13	2564.502	INSTALL MARKER	EACH		2	2
	2573.503	SEDIMENT CONTROL LOG TYPE WOOD FIBER	LIN FT		30	30
	2575.504	ROLLED EROSION PREVENTION CATEGORY 20	SQ YD		248	248
14	2575.505	SEEDING	ACRE		0.5	0.5
15	2575.505	DISK ANCHORING	ACRE		0.5	0.5
	2575.508	SEED MIXTURE 21-111	POUND		31	31
	2575.508	SEED MIXTURE 25-142	POUND		23	23
15	2575.509	MULCH MATERIAL TYPE 1	TON		1	1

GENERAL CONSTRUCTION NOTES:

- THE SUBSURFACE UTILITY INFORMATION IN THIS PLAN IS UTILITY QUALITY LEVEL D. THIS QUALITY LEVEL WAS DETERMINED ACCORDING TO THE GUIDELINES OF CI/ASCE 38-02, ENTITLED "STANDARD GUIDELINES FOR THE COLLECTION AND DEPICTION OF EXISTING SUBSURFACE UTILITY DATA".
- THE INFORMATION SHOWN ON THESE PLANS CONCERNING TYPE AND LOCATION OF UNDERGROUND UTILITIES ARE NOT GUARANTEED TO BE ACCURATE OR ALL INCLUSIVE. THE CONTRACTOR IS RESPONSIBLE FOR MAKING THEIR OWN DETERMINATION AS TO THE TYPE AND LOCATION OF UNDERGROUND UTILITIES AS MAY BE NECESSARY TO AVOID DAMAGE THERETO.
- CONTRACTOR IS RESPONSIBLE FOR NOTIFYING GOPHER STATE ONE CALL PRIOR TO CONSTRUCTION (PHONE NO. 1-800-252-1166).
- CONTRACTOR SHALL COORDINATE WORK WITH OTHER UTILITY CONTRACTORS, WORK MAY BE ADJACENT AND WITHIN THE PROJECT LIMITS. NO COMPENSATION WILL BE MADE FOR THE COORDINATION WITH THE UTILITIES.
- CONTRACTOR SHALL MAINTAIN CONSTRUCTION WORK WITHIN THE PROJECT LIMITS AS SHOWN ON THE PLANS. ANY DAMAGE OUTSIDE THE CONSTRUCTION LIMITS SHALL BE THE CONTRACTOR'S RESPONSIBILITY.
- (P) INDICATES PLANNED QUANTITY.

NOTES:

1. QUANTITY FOR AGGREGATE SURFACING CLASS 1 IS CALCULATED AT 4" IN THICKNESS BETWEEN STATIONS STA. 41+74 TO STA. 43+74 AND INCLUDES AN ADDITIONAL 50 TON TO ACCOUNT FOR NECESSARY ROAD REPAIRS DUE TO DAMAGE DONE DURING CONSTRUCTION.
2. PRECAST CONCRETE BOX CULVERT END SECTIONS SHALL BE TYPE 1 FOR A 7.5° SKEW, INLET END SECTION PIECE WILL CONSIST OF A WEIR WALL SHOWN IN DROP WALL DETAIL ON SHEET 3, WEIR WALL WILL BE MANUFACTURED BY PIPE MANUFACTURER.
3. MASTIC JOINT SEALER SHALL BE APPLIED TO THE ENTIRE JOINT AREA AND TO LIFT HOLE PLUGS. GEOTEXTILE MATERIAL SHALL ALSO BE INSTALLED ON THE ENTIRE JOINT AREA OF THE PIPE. MASTIC JOINT SEALER, GEOTEXTILE MATERIAL, AND PIPE TIES SHALL BE INCLUDED IN THE BID PRICE FOR PRECAST CONCRETE BOX CULVERTS.
4. ALL EXCESS EXCAVATION SHALL BE DISPOSED OF BY THE CONTRACTOR. COST OF SAID DISPOSAL SHALL BE INCLUDED IN THE BID PRICE FOR PRECAST CONCRETE BOX CULVERT.
5. PRIOR TO PERFORMING EXCAVATION AND EMBANKMENT OPERATIONS WITHIN THE PROJECT LIMITS THE CONTRACTOR SHALL SALVAGE AND STOCKPILE THE TOPSOIL IN A LOCATION OF THE CONTRACTOR'S CHOICE, ON THE PROJECT SITE. UPON COMPLETION OF ALL GRADING OPERATIONS, THE CONTRACTOR SHALL DEPOSIT AND SPREAD THE TOPSOIL IN A UNIFORM LAYER ON THE SUBSOIL. THIS WORK SHALL BE INCLUDED IN THE BID PRICE FOR REMOVAL OF THE EXISTING STRUCTURE. ANY EXCAVATED ROCK IS INCLUDED IN THE BID PRICE FOR THE REMOVAL OF BRIDGE.
6. EXISTING BRIDGE BECOMES THE PROPERTY OF THE CONTRACTOR AND SHALL BE DISPOSED OF OFF SITE. THE CONCRETE SHALL BE REMOVED AND DISPOSED AT AN APPROVED LANDFILL OR REUSED/RECYCLED ACCORDING TO LOCAL, STATE, AND FEDERAL REQUIREMENTS.
7. THE GRADATION FOR COARSE FILTER AGGREGATE SHALL CONFORM TO SPEC 3149.2H.
8. BACKFILLING SHALL OCCUR IN LIFTS NOT EXCEEDING 0.5 FEET IN DEPTH. THE CONTRACTOR SHALL USE HAND OPERATED COMPACTION EQUIPMENT AROUND THE PIPE CULVERT TO ATTAIN DENSITY.
9. QUANTITIES AND TILE SIZES ARE ESTIMATED BY COMMUNICATION WITH THE LAND OWNER AND SHALL BE VERIFIED BY THE CONTRACTOR PRIOR TO REPLACEMENT OF THE TILE.
10. BID ITEM INCLUDES A 10' CORRUGATED STEEL PIPE OR PE DUAL WALL PPE, RODENT GUARD, ANY FITTINGS REQUIRED TO MAKE CONNECTION, AND DISPOSAL OF EXISTING MATERIAL REMOVAL.
11. INSTALLATION SHALL BE IN ACCORDANCE WITH SPECS. 2511 & 3601. TYPE 7 GEOTEXTILE FILTER SHALL CONFORM TO SPEC. 3733. THIS ITEM IS INCLUDED IN THE BID PRICE FOR THE PLACEMENT OF RIP RAP.
12. THE CONTRACTOR SHALL USE QUARRY RUN RIP RAP.
13. CULVERT MARKER TO BE FURNISHED BY THE COUNTY.
14. THE AREAS TO BE SEEDED SHALL BE COMPRISED OF ALL DISTURBED AREAS WITHIN THE PROJECT LIMITS. PRIOR TO THE SEEDING OPERATION THE AREAS SHALL BE CLEARED OF ALL DEBRIS (INCLUDING TREE ROOTS, WEEDS, ROCKS, ETC.). ANY DEBRIS ENCOUNTERED WHILE PREPARING THE AREAS FOR SEEDING SHALL BE DISPOSED OF BY THE CONTRACTOR OFF THE PROJECT IN A SUITABLE DISPOSAL AREA PROVIDED BY THE CONTRACTOR AS APPROVED BY THE ENGINEER. THE PREPARATION FOR SEEDING, REMOVAL AND HAULING OF DEBRIS IS INCLUDED IN THE BID PRICE FOR SEEDING.
15. MULCH MATERIAL TYPE 1 SHALL BE USED IN DISTURBED AREAS IN WHICH BLANKET IS NOT USED AND SHALL BE DISK ANCHORED.

UTILITY CONTACTS
LINCOLN COUNTY ENVIRONMENTAL OFFICE 221 NORTH WALLACE AVENUE P.O. BOX 66 IVANHOE, MN (507)694-1344

BASIS FOR PLANNED QUANTITIES	
AGGREGATE SURFACING CLASS 1	140 LBS./CUBIC FOOT (CV)
QUARRY RUN RIP-RAP	1.3 TONS/CUBIC YARD
SEED MIXTURE 21-111	62 LBS./ACRE (PLS RATE)
SEED MIXTURE 25-142	45 LBS./ACRE (PLS RATE)
MULCH MATERIAL TYPE 1	2 TONS / ACRE
GRANULAR BACKFILL	1.8 TONS / CUBIC YARD

STANDARD PLATES	
PLATE NO.	DESCRIPTION
8000 K	CHANNELIZERS TYPE A, TYPE B, TYPE C.
*THESE STANDARD PLATES ARE APPROVED BY THE FEDERAL HIGHWAY ADMINISTRATION AND SHALL APPLY ON THIS PROJECT.	

PROPOSED TYPICAL SECTION TOWNSHIP ROAD

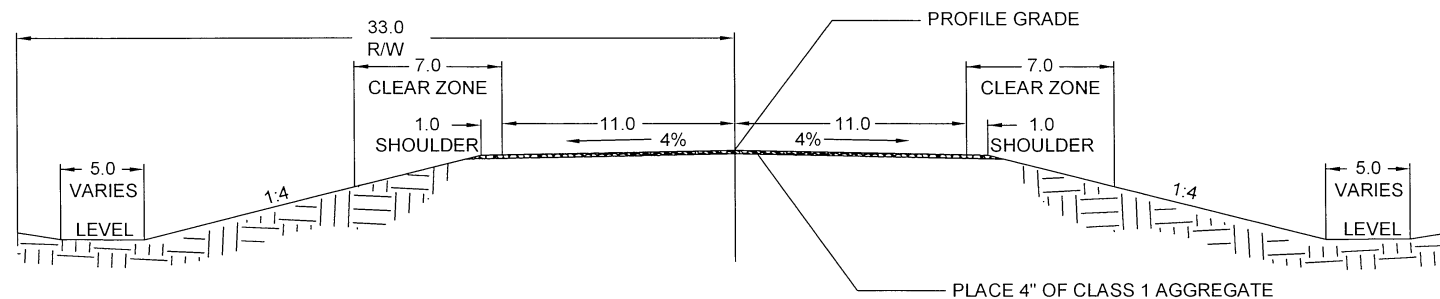

ESTIMATED QUANTITIES

CERTIFIED BY *Joseph M. Hillman* LIC. NO. 54947 DATE: 1-4-23
LICENSED ENGINEER

S.A.P. NO. 041-599-069 SHEET NO. 2 OF 13

ELEVATION VIEW

NO SCALE
SOUTH ← NORTH

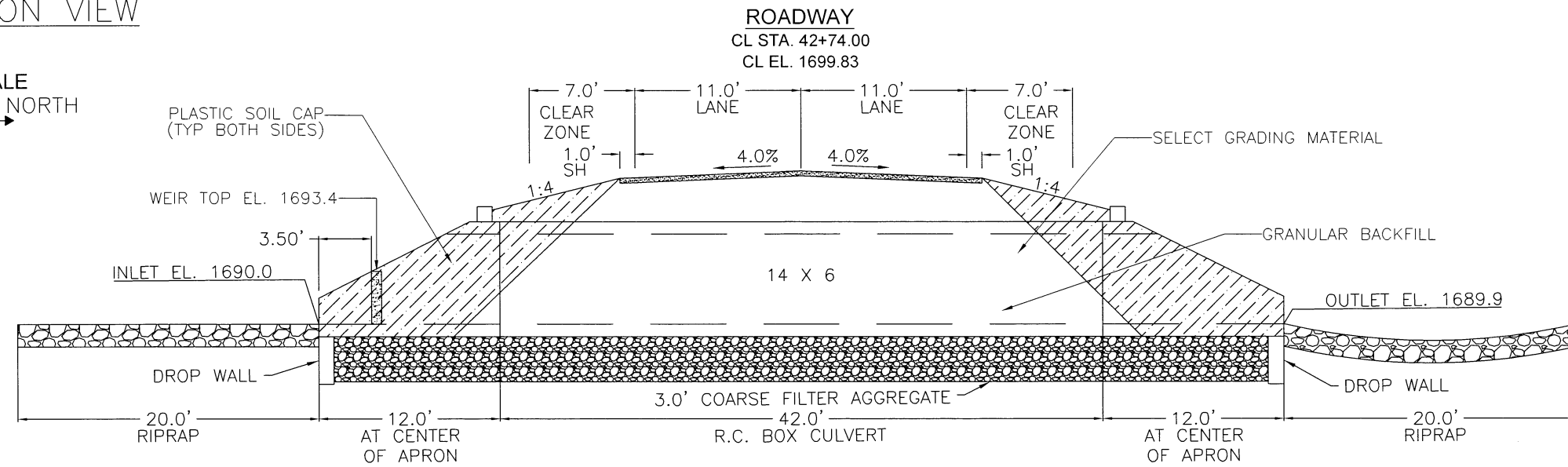

DESIGN DATA

DESIGNED IN ACCORDANCE WITH 2017 AASHTO LRFD BRIDGE DESIGN SPECIFICATIONS.

HL-93 LIVE LOAD
BARREL A INSIDE WIDTH = 14 FT
BARREL A INSIDE HEIGHT = 6 FT

BARREL LENGTH = 42 FT EACH
EST. MIN. FILL DEPTH (A) = 2.7 FT
EST. MAX. FILL DEPTH (B) = 3.1 FT
SKEW ANGLE = 7.5°

DESIGN SPEED = 30 MPH
CURRENT ADT (2022) = LESS THAN 50
PROJECTED ADT (2042) = LESS THAN 50

HL-93 LRFR
BRIDGE OPERATING RATING FACTOR RF = 1.3

LIST OF SHEETS

NO.	DESCRIPTION
1.	TITLE SHEET
2.	ESTIMATED QUANTITIES
3.	GENERAL PLAN AND ELEVATION
4.	STAKEOUT
5-6.	BARREL & END SECTION DETAILS
7.	EMBANKMENT PROTECTION
8.	EROSION & SEDIMENT CONTROL PLAN
9.	EROSION & SEDIMENT CONTROL DETAILS
10.	PLAN & PROFILE
11.	BRIDGE SURVEY SHEET
12.	SWPPP
13.	TRAFFIC CONTROL

CONSTRUCTION NOTES:

THE 2020 EDITION OF THE MINNESOTA DEPARTMENT OF TRANSPORTATION "STANDARD SPECIFICATIONS FOR CONSTRUCTION" SHALL GOVERN.

ALL EXPOSED CONCRETE EDGES SHALL BE FORMED WITH A 1/2" OR 3/4" CHAMFER UNLESS OTHERWISE NOTED.

CONSTRUCTION SHALL BE IN ACCORDANCE WITH SPEC. 2411 AND 2412, EXCEPT AS NOTED.

REFER TO REMAINDER OF GRADING PLAN FOR SUPERSTRUCTURE EXCAVATION AND BACKFILL. SPEC. 2451.

THE BAR SIZES SHOWN IN THIS PLAN ARE IN U.S. CUSTOMARY DESIGNATIONS.

REFER TO ESTIMATED QUANTITIES SHEET FOR THE SUBSURFACE UTILITY INFORMATION.

I HEREBY CERTIFY THAT THIS PLAN WAS PREPARED BY ME OR UNDER MY DIRECT SUPERVISION AND THAT I AM A DULY LICENSED PROFESSIONAL ENGINEER UNDER THE LAWS OF THE STATE OF MINNESOTA.

SIGNED: *Joseph M. Wilson* DATE: 11-29-22
LICENSED PROFESSIONAL ENGINEER
NAME: JOSEPH M. WILSON LIC NO. 54947

ELEVATION VIEW

NOTES:

- BACKFILLING FROM GRANULAR BAKFILL TO 2' ABOVE THE PIPE SHALL BE WITH SELECT GRADING MATERIAL AND IS INCLUDED IN THE BID PRICE FOR THE PRECAST CONCRETE BOX CULVERT.
- BACKFILLING FROM 2' ABOVE THE PIPE TO GRADING SHALL BE WITH SELECT GRADING MATERIAL AND IS INCLUDED IN THE BID PRICE FOR THE REMOVAL OF THE EXISTING BRIDGE.

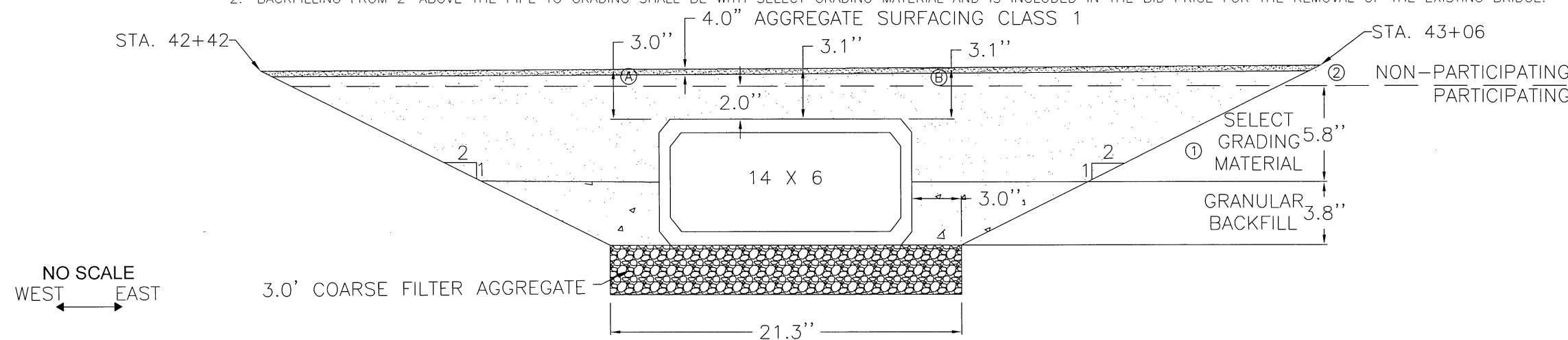

NO SCALE
WEST ← EAST

DROP WALL DETAILS

NO SCALE
WEST ← EAST

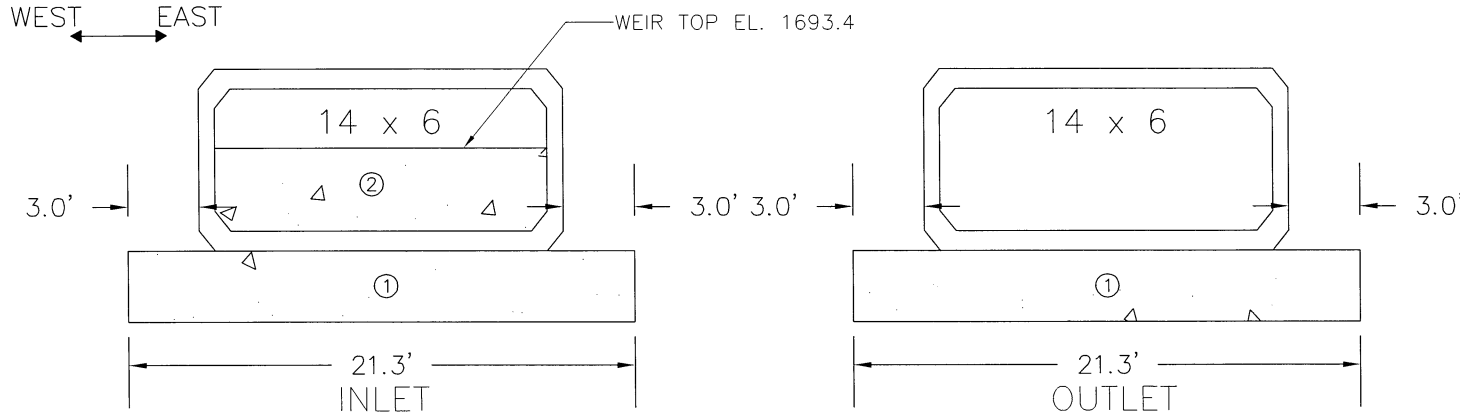

DROP WALL NOTES:

- DROP WALL ON 14 X 6 END SECTIONS SHALL EXTEND 3' BEYOND THE WALLS OF THE END SECTION ON THE OUTERMOST SIDE. THE PLACEMENT OF THE DROP WALLS SHALL BE INCLUDED IN THE BID FOR THE END SECTION.
- WEIR WALL WILL BE PLACE 3.5' FROM END OF APRON, WEIR WALL WILL BE 3.4' IN HEIGHT. WEIR WILL BE PLACE IN THE INLET OF BOX CULVERT, SPECS WILL BE DETERMINED BY MANUFACTURE OF PIPE.

SCALE: 1"=30'

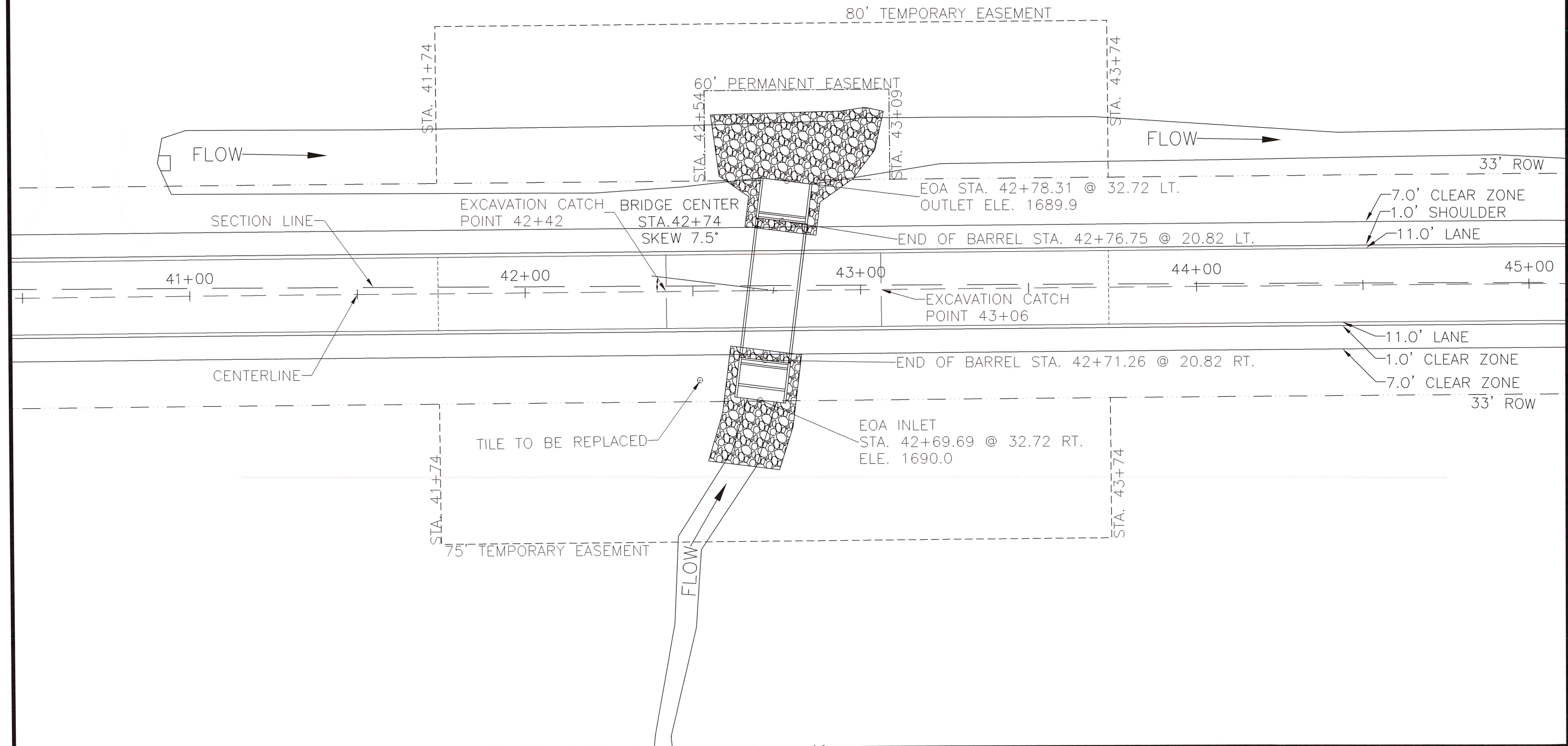

STAKEOUT

CERTIFIED BY *Joseph Witten* LIC. NO. 54947 DATE: 11-29-22
 LICENSED ENGINEER

S.A.P. NO. 041-599-069 SHEET NO. 4 OF 13

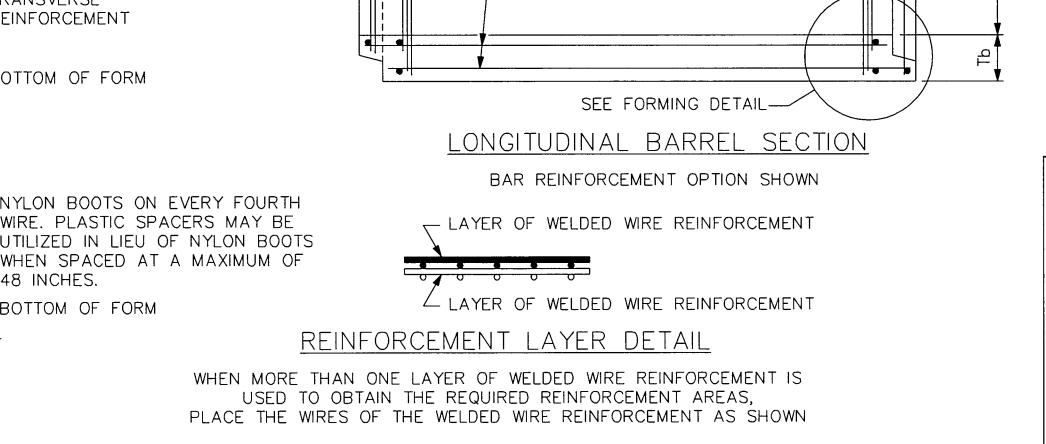
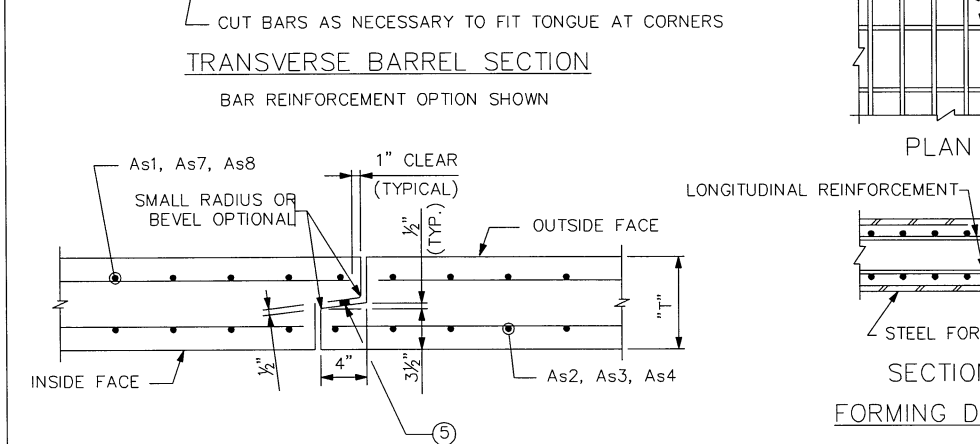
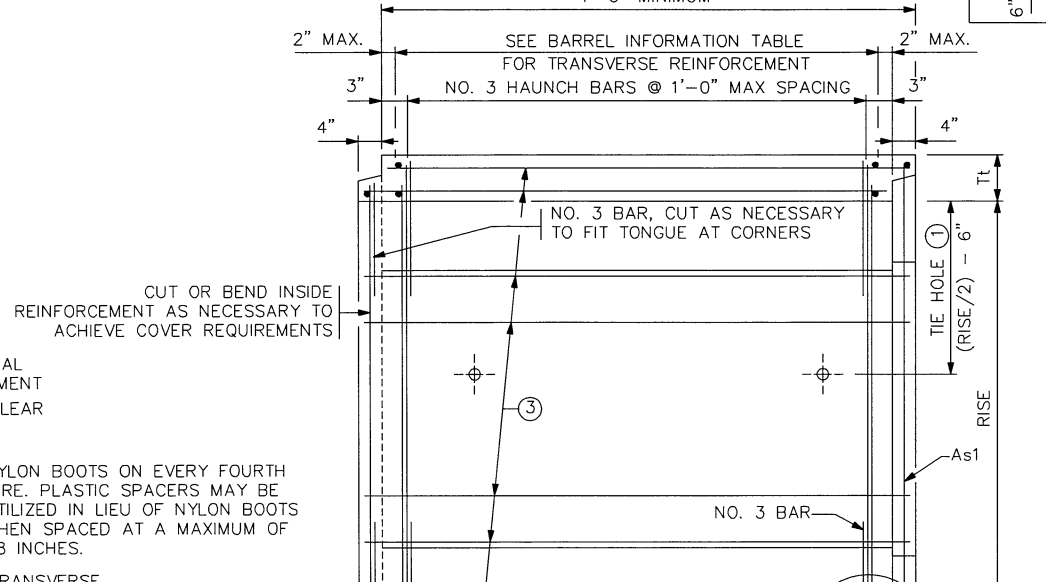
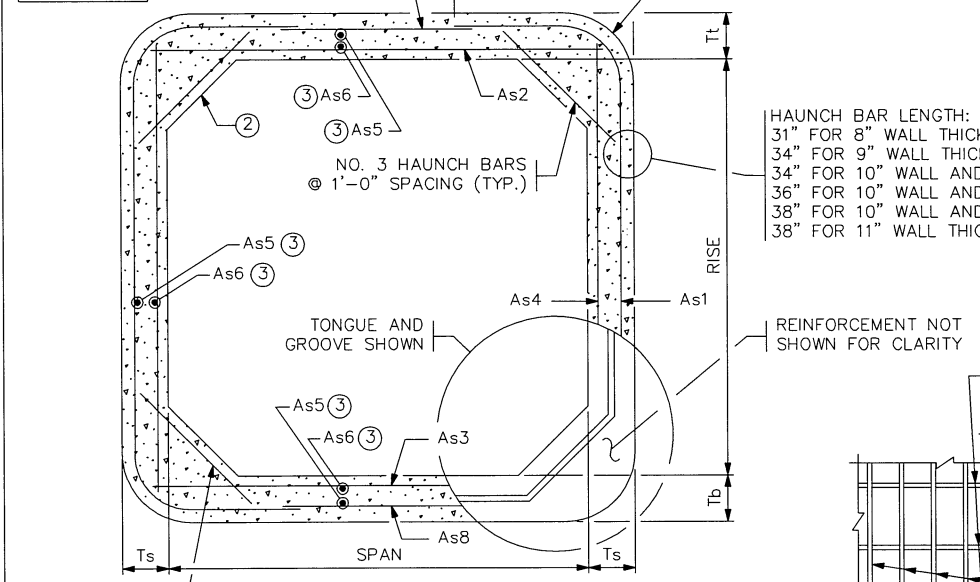
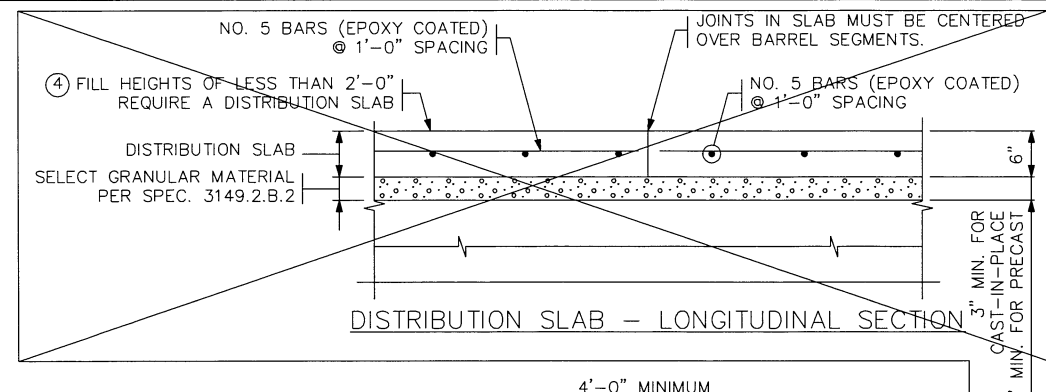
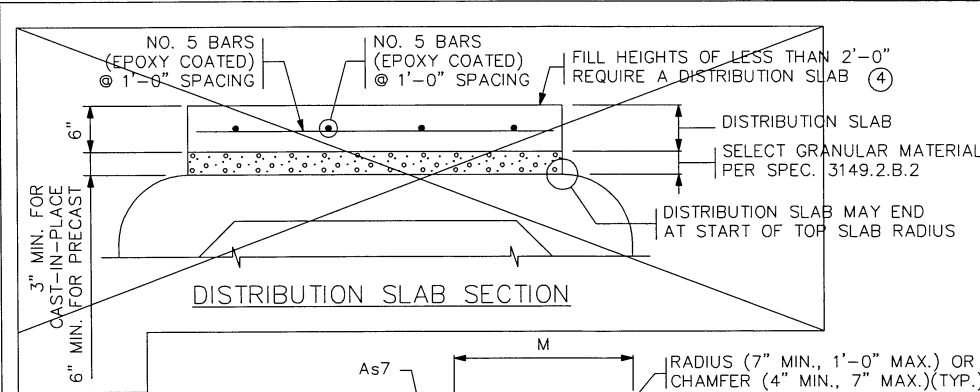

CONSTRUCTION NOTES

CONSTRUCT CULVERTS PER SPEC. 2412 EXCEPT AS NOTED.

REFER TO THE GENERAL PLAN AND ELEVATION SHEET FOR THE DISTANCE BETWEEN BARRELS OF ADJACENT BOXES AND TO STANDARD FIGURE 5-395.115 FOR MATERIAL REQUIREMENTS FOR FILL BETWEEN ADJACENT BOXES.

PROVIDE WELDED WIRE REINFORCEMENT, SHEAR REINFORCEMENT AND REINFORCEMENT BARS PER THE APPLICABLE REQUIREMENTS OF AASHTO M259.

1 1/2" MIN. AND 2" MAX. CONCRETE COVER ON ALL REINFORCEMENT, INCLUDING SHEAR REINFORCEMENT, EXCEPT FOR TONGUE AND GROOVE DETAIL.

ANY OF THE FOLLOWING COMBINATIONS OF STEEL REINFORCEMENT MAY BE USED:

- (a) 1 OR 2 LAYERS OF WELDED WIRE REINFORCEMENT OR
- (b) 1 LAYER OF WELDED WIRE REINFORCEMENT AND 1 LAYER OF REINFORCEMENT BARS OR
- (c) 1 LAYER OF REINFORCEMENT BARS.

DEVELOP REINFORCEMENT IN ACCORDANCE WITH AASHTO "LRFD BRIDGE DESIGN SPECIFICATIONS". IF BAR REINFORCEMENT IS SUBSTITUTED FOR WELDED WIRE REINFORCEMENT, INCREASE THE AREA OF REINFORCEMENT BY 8%, AND SUBMIT DESIGN CALCULATIONS VERIFYING COMPLIANCE WITH AASHTO 5.7.3.4. "CONTROL OF CRACKING BY DISTRIBUTION OF REINFORCEMENT".

MAXIMUM SIZE OF REINFORCEMENT BARS IS NO. 6. THE MAXIMUM WELDED WIRE REINFORCEMENT SIZE IS W23 PER LAYER (MAXIMUM OF 2 LAYERS).

SPACE CENTER TO CENTER OF TRANSVERSE WIRES NOT LESS THAN 2" NOR MORE THAN 4". SPACE CENTER TO CENTER OF LONGITUDINAL WIRES NOT MORE THAN 8".

WHEN USING As1, As7, AND As8 REINFORCEMENT AS ONE CONTINUOUS CAGE WITH SPLICES OCCURRING IN THE CENTER OF THE TOP AND BOTTOM OF THE BOX SECTION, THE MIN. LAP LENGTH FOR THE As7 AND As8 IS 15".

WELDING IS NOT PERMITTED ON REINFORCEMENT BARS OR WELDED WIRE REINFORCEMENT, EXCEPT THAT THE ORIGINAL WELDING REQUIRED TO MANUFACTURE WIRE REINFORCEMENT IS ACCEPTABLE.

WHEN REINFORCEMENT IS CUT, PLACE ADDITIONAL REINFORCEMENT ON BOTH SIDES OF THE CUT MEMBER TO REPLACE OR EXCEED THE CUT STEEL.

USE CONCRETE MIX NO. 3W82 WITH NO CALCIUM CHLORIDE ALLOWED.

SHOP DRAWING APPROVAL PER SPEC. 3238.2.A IS NOT REQUIRED UNLESS OPENINGS OR ATTACHMENTS ARE PLACED ON A BARREL SEGMENT.

COMPACT THE FIRST 1.5' (LOOSE) OF FILL ABOVE THE BOX WITH LIGHT COMPACTION EQUIPMENT SUCH AS PLATE COMPACTORS OR WALK BEHIND ROLLERS.

TRANSVERSE REINFORCEMENT IS PARALLEL TO THE CULVERT SPAN. LONGITUDINAL REINFORCEMENT IS PERPENDICULAR TO THE CULVERT SPAN.

- ① USE 1" DIAMETER CULVERT TIES. SEE STANDARD PLATE NO. 3145 FOR DETAILS.
- ② USE 12" VERTICAL, 12" HORIZONTAL HAUNCHES ON ALL BOX SIZES.
- ③ PLACE LONGITUDINAL REINFORCEMENT DENOTED AS As5 AND As6 IN ALL SLABS AND WALLS WITH A MINIMUM OF 0.06 SQ. IN./FT.
- ④ ROADWAY OR SHOULDER FILL HEIGHTS OF LESS THAN 2'-0" REQUIRE A 6" THICK DISTRIBUTION SLAB WITH CONCRETE MIX 3552.
- ⑤ REFER TO SPEC, 2412 FOR SEALANT REQUIREMENTS.

PLACE CAST-IN-PLACE DISTRIBUTION SLABS WITH 3" MIN. SELECT GRANULAR MATERIAL PER SPEC. 3149.2.B.2 BETWEEN BARREL AND DISTRIBUTION SLAB.

PRECAST DISTRIBUTION SLABS MAY BE USED FOR FILL HEIGHTS OVER 1'-0". PROVIDE 6" MINIMUM SELECT GRANULAR MATERIAL PER SPEC. 3149.2.B.2 BETWEEN BARREL AND SLAB.

EXTEND THE WIDTH OF THE DISTRIBUTION SLAB TO THE OUTSIDE EDGES OF THE ROADWAY SHOULDERS UNLESS DIRECTED BY THE ENGINEER.

REDESIGN THE DISTRIBUTION SLAB PER THE MnDOT PAVEMENT DESIGN MANUAL IF IT IS USED AS PAVEMENT SURFACE.

PAVEMENT FOR THE DISTRIBUTION SLAB AND SELECT GRANULAR MATERIAL BENEATH THE SLAB IS CONSIDERED INCIDENTAL.

LOCATION	SIZE	CLASS	f'c (P.S.I.)	FILL HEIGHT RANGE (FT.)	DISTRIBUTION SLAB REQUIRED *	RECESSED TIE RODS REQUIRED **	DIMENSIONS					WEIGHT (LBS./FT.)	WELDED WIRE REINFORCEMENT												
							SPAN (FT.)	RISE (FT.)	Tt (IN.)	Tb (IN.)	Ts (IN.)		As1		As2		As3		As4		As7		As8		
													AREA (IN. ² /FT.)	LENGTH (FT.)	AREA (IN. ² /FT.)	LENGTH (FT.)	AREA (IN. ² /FT.)	LENGTH (FT.)	AREA (IN. ² /FT.)	LENGTH (FT.)	AREA (IN. ² /FT.)	LENGTH (FT.)	AREA (IN. ² /FT.)	LENGTH (FT.)	
42+74	14X6	1	5000	<3	NO	NO	14'	6'	10"	10"	8"	5350	0.90	14'-8"	3'-9"	0.91	14'-6"	0.88	14'-6"	0.20	6'-6"	0.24	10'-11"	0.24	10'-11"
-	-	-	-	-	-	-	-	-	-	-	-	-	-	-	-	-	-	-	-	-	-	-	-	-	-

REVISION: FEBRUARY 22, 2018

APPROVED: MARCH 24, 2011

Nancy Subenberger
STATE BRIDGE ENGINEER

ALL CLASS 1 CULVERTS WITH FILL HEIGHTS OF LESS THAN 2'-0" REQUIRE A DISTRIBUTION SLAB. IF A DISTRIBUTION SLAB IS NOT REQUIRED, INDICATE "NO" IN THIS BOX.

** FOR PEDESTRIAN CULVERT APPLICATIONS HIDE-AWAY OR RECESSED TIE CONNECTIONS ARE REQUIRED, SEE STANDARD PLATE 3145. IF REQUIRED, INDICATE "YES" IN THIS BOX.

** BOX CULVERTS WITH SPANS FROM 6 TO 14 FT. ARE DESIGNED FOR HL-93 LIVE LOADS (AASHTO LRFD 3.6.2.1) NOT INCLUDING THE DESIGN LANE LOAD. BOXES WITH SPANS OF 16 FT. ARE DESIGNED FOR HL-93 LIVE LOADS INCLUDING THE DESIGN LANE LOAD.

STATE AID PROJ. NO 041-599-069 (270TH ST.) STA. 42+74

FIG. 5-395.101(A)

CERTIFIED BY: *Joseph M. Wilson* 11-29-22
LICENSED PROFESSIONAL ENGINEER DATE

NAME: JOSEPH M. WILSON LIC. NO. 54947

TITLE: PRECAST CONCRETE BARREL DETAILS

DES: _____ DR: _____ APPROVED: _____
CHK: _____ CHK: _____

SHEET NO. 5 OF 13 SHEETS

BRIDGE NO. 41J84

CONSTRUCTION NOTES

SEE STANDARD FIG. 5-395.101(A) AND FIG. 5-395.101(B) FOR ADDITIONAL DIMENSIONS AND CONSTRUCTION NOTES.

USE CONCRETE MIX NO. 3W82 WITH NO CALCIUM CHLORIDE ALLOWED.

ALL END SECTIONS REQUIRE CURB ON LINTEL BEAM.

ON ALL END SECTIONS FOR WATERWAYS, USE DROPWALLS ON INLET AND OUTLET ENDS.

SEE STANDARD FIG. 5-395.115 FOR EMBANKMENT PROTECTION.

FINISH ALL EXPOSED EDGES OF CONCRETE WITH 1/2" OR 3/4" CHAMFER OR RADIUS UNLESS OTHERWISE NOTED.

MAXIMUM SIZE OF REINFORCEMENT BARS IS NO. 6, EXCEPT NO. 7 OR 8 BARS MAY BE USED FOR Abt ON SPANS GREATER THAN 14'. THE MAXIMUM WELDED WIRE REINFORCEMENT SIZE IS W23 PER LAYER (MAXIMUM OF 2 LAYERS).

- ① WITH DOUBLE BOXES LOCATE DROPWALL JOINTS BETWEEN END SECTIONS. SEE STANDARD FIG. 5-395.111 FOR ALTERNATE DROPWALLS. LIMITS OF EXCAVATION FOR DROPWALL ARE APPROXIMATELY THE SAME AS DROPWALL DIMENSIONS. DROPWALL CONCRETE MIX IS 3S52, OR 3Y82 IF PRECAST. FURNISHING AND INSTALLATION OF DROPWALL TO BE INCLUDED IN PRICE BID FOR END SECTIONS. DROPWALL NOT REQUIRED FOR NON-WATERWAY USE.
- ② CHECK LOCATION TO DETERMINE WHETHER A TONGUE OR A GROOVE IS USED.
- ③ FILL HOLE WITH GROUT. GROUT CONSISTS OF 1 PART CEMENT AND 2 PARTS SAND. USE TYPE 1A AIR ENTRAINED PORTLAND CEMENT. GROUT MIX MAXIMUM SLUMP IS 4".
- ④ 3'-6" MIN. TONGUE AND 3'-7" MIN. GROOVE FOR CULVERTS WITH 6'-0" SPANS. 5'-0" MIN. TONGUE AND 5'-1" MIN. GROOVE FOR CULVERTS WITH SPANS GREATER THAN 6'-0". CENTER TONGUE AND GROOVE ON C OF EACH APRON JOINT. TONGUE AND GROOVE JOINT ON ALL THREE SIDES OF APRON IS PERMISSIBLE.
- ⑤ WELDED WIRE REINFORCEMENT OF EQUAL AREA MAY BE SUBSTITUTED FOR REBAR.
- ⑥ APRON TOP AND BOTTOM SLAB THICKNESS MAY BE 8" FOR CULVERTS WITH 6' SPANS ONLY. BOTTOM SLAB THICKNESS MAY BE INCREASED UP TO 2" MAX. PROVIDED CONCRETE COVER IS 1 1/2" MIN., 2" MAX.
- ⑦ 10" MINIMUM TOP SLAB FOR 14' AND 16' SPANS.
- ⑧ PLACE LONGITUDINAL REINFORCEMENT PERPENDICULAR TO THE CULVERT SPAN WITH A MINIMUM OF 0.06 SQUARE INCHES PER PERIPHERAL FOOT ON ALL FACES OF THE BARREL.
- ⑨ REFER TO SPEC. 2412 FOR SEALANT REQUIREMENTS.

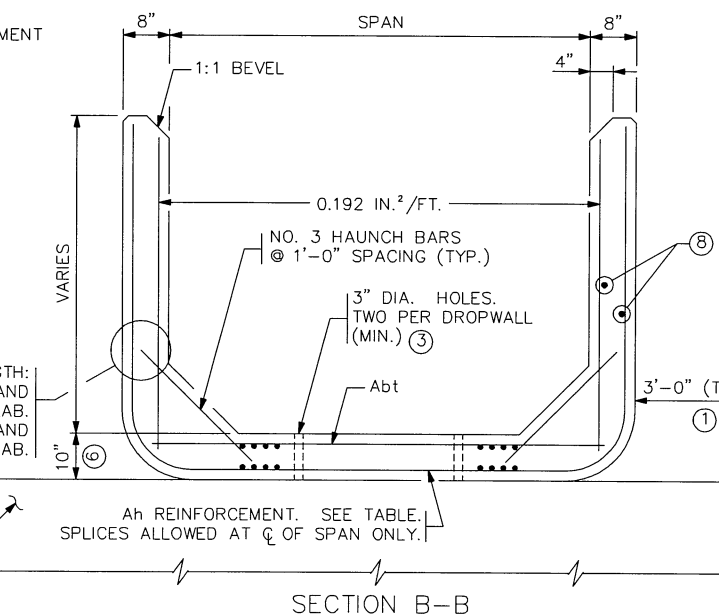
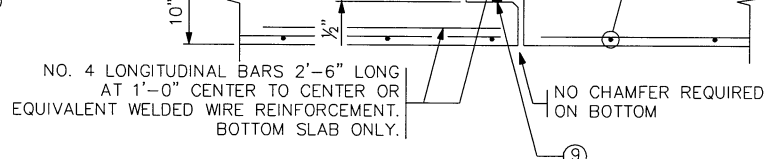
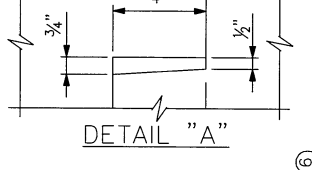
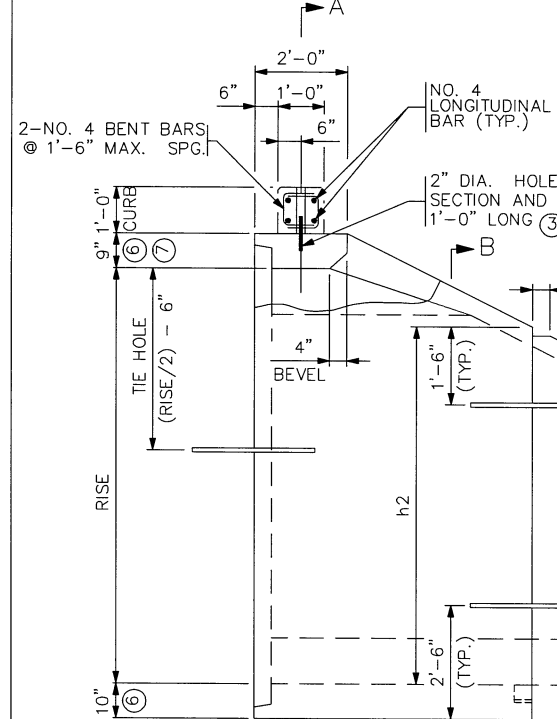
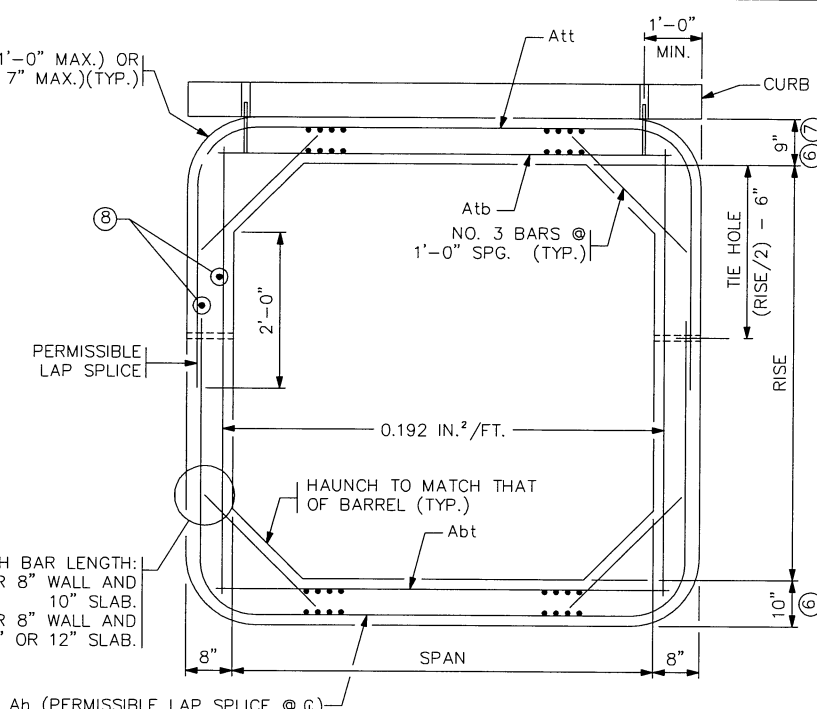
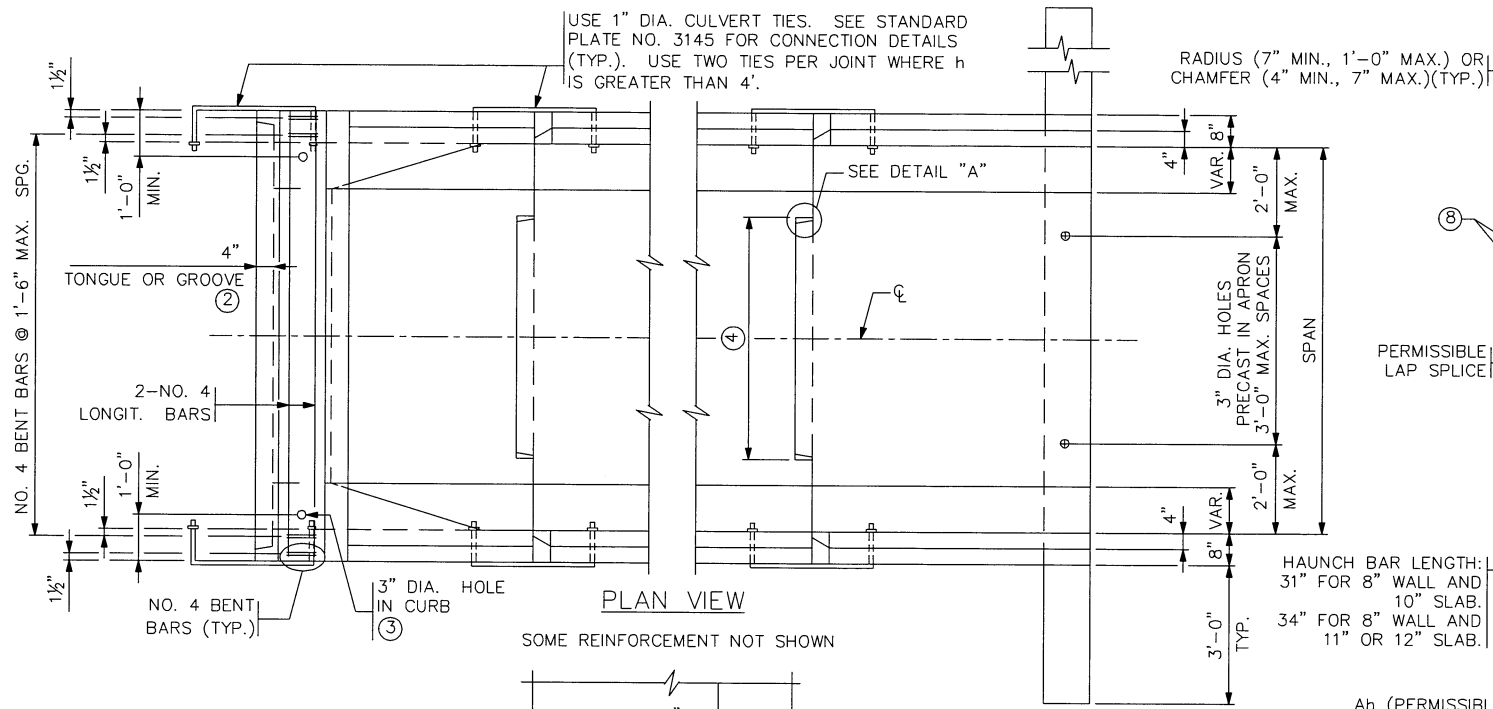

Att, Abt REINFORCEMENT

SPAN (FT.)	Att (IN²/FT.)	Abt (IN²/FT.)
6	0.27	0.44
8	0.47	0.60
10	0.62	0.74
12	0.88	1.06
14	1.20	1.58
16	1.52	2.09

Abt REINFORCEMENT

SPAN (FT.)	Abt (IN²/FT.)
6-10	0.20
12	0.30
14	0.39
16	0.39

APRON DIMENSIONS & Ah REINFORCEMENT

RISE FT.	L FT.	SECTION 1		SECTION 2		SECTION 3		SECTION 4		SECTION 5						
		X	Ah	h2	Y	Ah	h3	Z	Ah	h4	ZZ	Ah	h5	ZZZ	Ah	h6
4	8	8'(4')	0.192	1'-9"(3'-9")	(4')	(0.192)	(1'-9")									
5	10	6'	0.192	3'-9"	4'	0.192	1'-9"									
6	12	6'	0.192	4'-9"	6'	0.192	1'-9"									
7	14	6'	0.192	5'-9"	8'(4')	0.192	1'-9"(3'-9")	(4')	(0.192)	(1'-9")						
8	16	6'	0.20	6'-9"	6'	0.192	3'-9"	4'	0.192	1'-9"						
9	18	6'	0.29	7'-9"	6'	0.192	4'-9"	6'	0.192	1'-9"						
10	20	6'	0.42	8'-9"	6'	0.29	5'-9"	8'(4')	0.192	1'-9"(3'-9")	(4')	(0.192)	(1'-9")			
11	22	6'	0.60	9'-9"	6'	0.42	6'-9"	6'	0.192	3'-9"	4'	0.192	1'-9"			
12	24	6'	0.78	10'-9"	6'	0.60	7'-9"	6'	0.20	4'-9"	6'	0.192	1'-9"			
13	26	6'	1.03	11'-9"	6'	0.78	8'-9"	6'	0.28	5'-9"	8'(4')	0.192	1'-9"(3'-9")	(4')	(0.192)	(1'-9")
14	28	6'	1.38	12'-9"	6'	1.03	9'-9"	6'	0.40	6'-9"	6'	0.192	3'-9"	4'	0.192	1'-9"

NOTE: Ah IS AREA OF REINFORCEMENT PER FOOT OF LENGTH (IN²/FT.) VALUES IN () MAY BE USED FOR END SECTIONS WITH SPANS OF 14' AND 16' ONLY.

SIDE ELEVATION

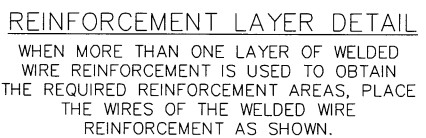

REVISION: FEBRUARY 22, 2018
 APPROVED: MARCH 24, 2011
 Nancy M. Wilson
 STATE BRIDGE ENGINEER

STATE AID PROJ. NO 041-599-069 (270TH ST.) STA. 42+74 FIG. 5-395.102

CERTIFIED BY: *Joseph M. Wilson* 11-29-22 DATE: 11-29-22 TITLE: PRECAST CONCRETE END SECTION TYPE I - SINGLE OR DOUBLE BARREL FOR SKEWS UP TO 7 1/2'

DES: _____ DR: _____ APPROVED: _____
 CHK: _____ CHK: _____

NAME: JOSEPH M. WILSON LIC. NO. 54947 SHEET NO. 6 OF 13 SHEETS BRIDGE NO. 41J84

CONSTRUCTION NOTES

THIS PLAN SHEET IS FOR CULVERT EMBANKMENT PROTECTION ONLY. REFER TO THE GRADING PLANS FOR ADDITIONAL RIPRAP OR OTHER SCOUR PROTECTION MEASURES.

PROVIDE RIPRAP PER SPECS. 2511 AND 3601.

① FOR TYPE OF GEOTEXTILE FILTER MATERIAL REQUIRED, SEE SPEC. 3733. PROVIDE GEOTEXTILE STRIPS CONTINUOUS WITHOUT OVERLAPS, EXCEPT FOR THE TOP STRIP, WHICH SHOULD SHINGLE VERTICAL STRIPS. BURY THE TOP EDGE TO PREVENT UNDERMINING.

② IF THE DISTANCE BETWEEN DOUBLE BARRELS IS LESS THAN 2'-0" USE EITHER PEA ROCK OR LEAN MIX BACKFILL (SPEC. 2520) BETWEEN THE CULVERTS AS APPROVED BY THE ENGINEER. IF PEA ROCK IS USED PROVIDE APPROVED GROUT SEEPAGE CUTOFF CORE, MINIMUM 12" THICK BETWEEN THE CULVERT'S TWO ENDS AND PROVIDE CLASS I GROUTED RIPRAP IN LIEU OF CLASS III RIPRAP.

③ REFER TO THE GENERAL PLAN AND ELEVATION SHEET FOR THE DISTANCE BETWEEN BARRELS OF ADJACENT BOXES.

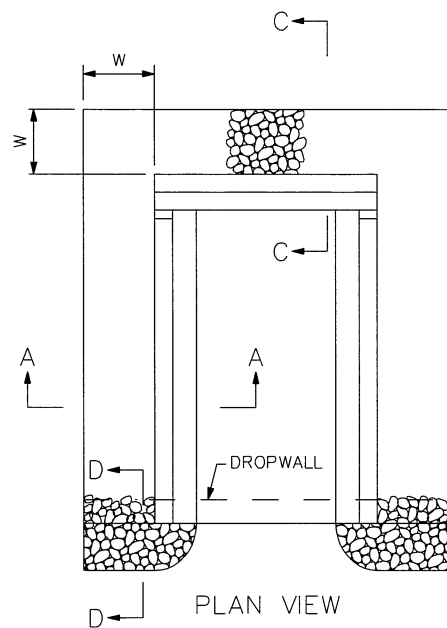

PLAN VIEW

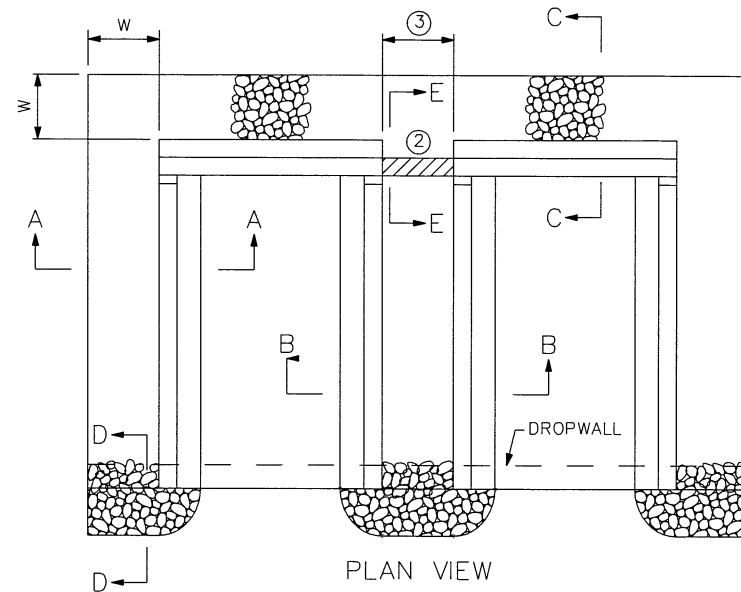

PLAN VIEW

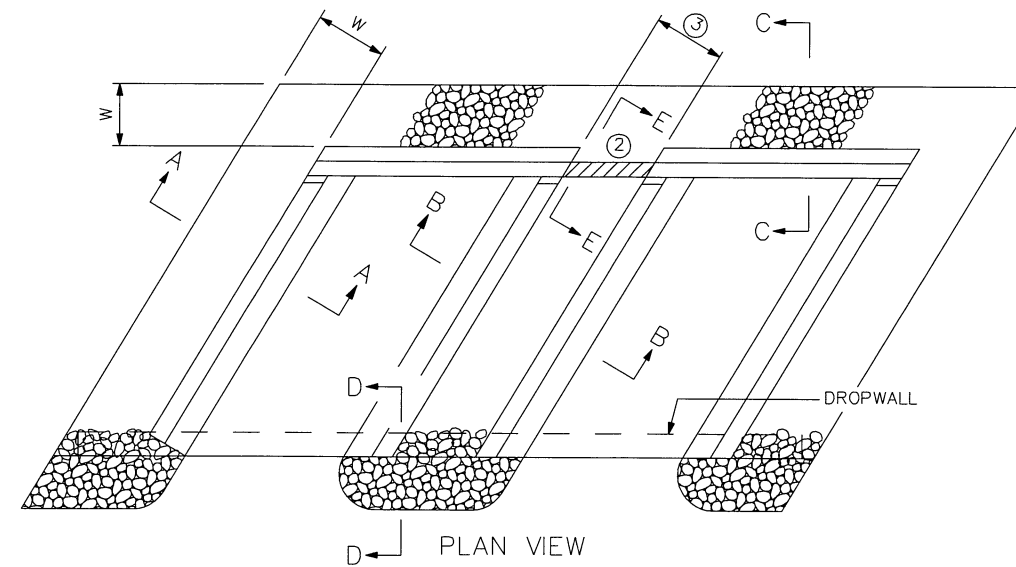

PLAN VIEW

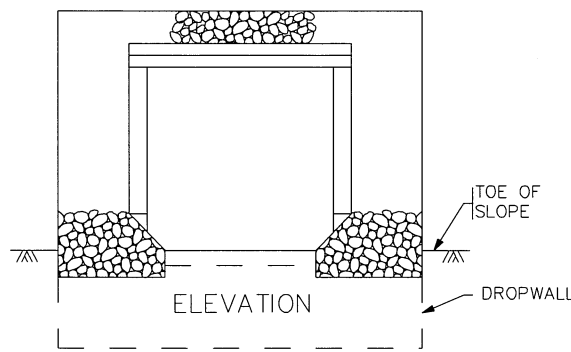

ELEVATION

SINGLE BARREL

CLASS III OR IV SHOWN FOR SKEWS UP TO 7½'

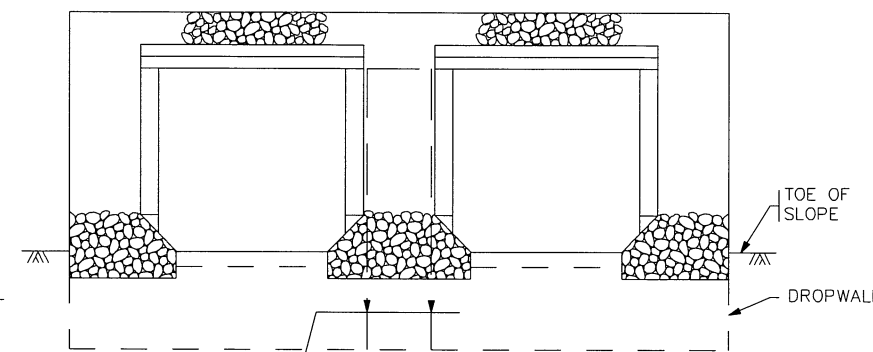

ELEVATION

MULTIPLE BARREL

FOR SKEWS UP TO 7½' CLASS III OR IV SHOWN DOUBLE BARREL SHOWN

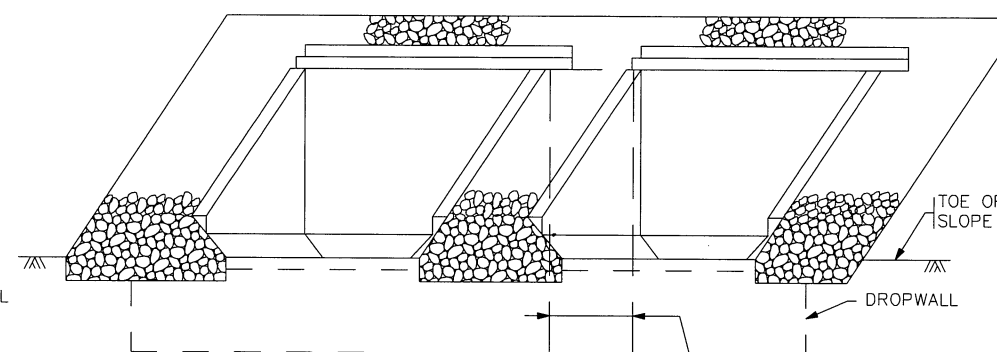

ELEVATION

MULTIPLE BARREL

FOR SKEWS OVER 7½' CLASS III OR IV SHOWN DOUBLE BARREL SHOWN, OTHER BARREL CONFIGURATIONS SIMILAR.

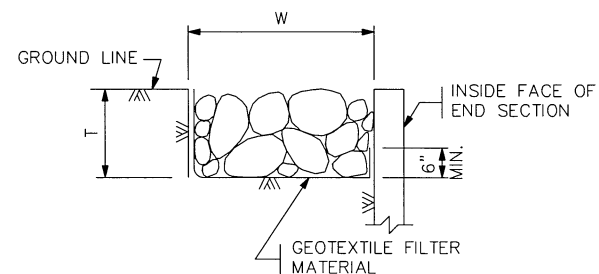

SECTION A-A

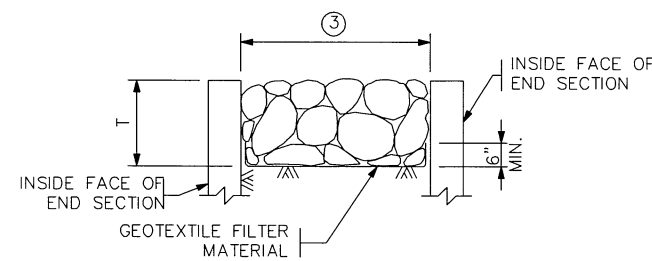

SECTION B-B

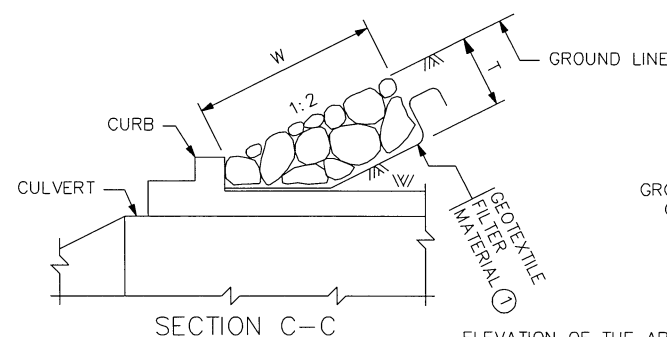

SECTION C-C

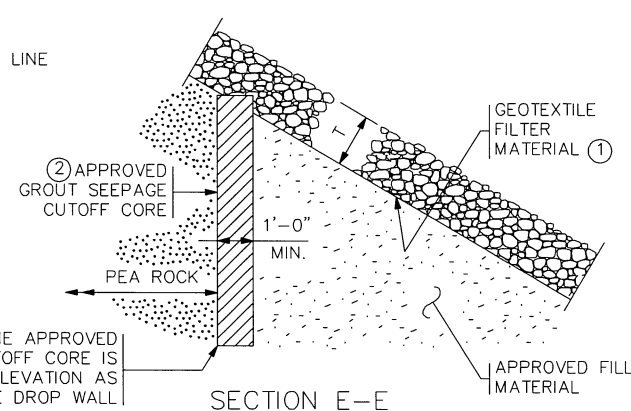

SECTION E-E

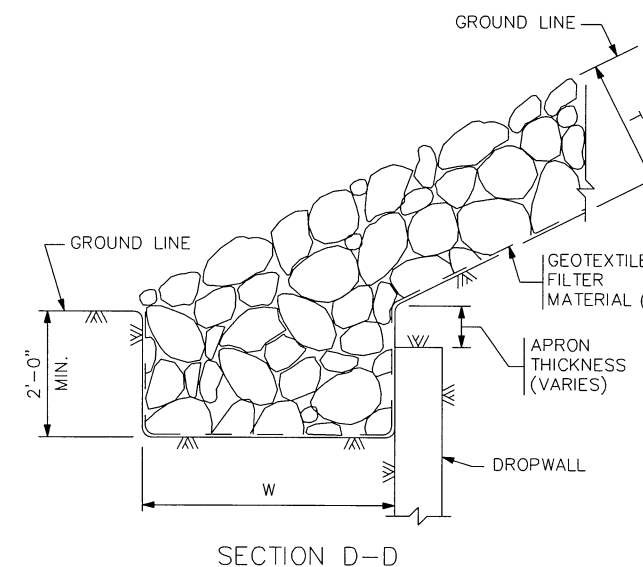

SECTION D-D

RIPRAP CLASS

RIPRAP CLASS	RIPRAP CLASS	T	W
☒	III	1'-6"	3'-0"
☐	IV	2'-0"	4'-0"

REVISION: 10-09-2015

APPROVED: SEPTEMBER 11, 2014

Nancy Dubenberger
STATE BRIDGE ENGINEER

ELEVATION OF THE APPROVED GROUT SEEPAGE CUTOFF CORE IS TO BE THE SAME ELEVATION AS THE BOTTOM OF THE DROP WALL

STATE AID PROJ. NO 041-599-069 (270TH ST.) STA. 42+74		FIG. 5-395.115	
CERTIFIED BY <i>Joseph M. Wilson</i>	DATE 11-29-22	DES:	DR:
NAME: JOSEPH M. WILSON	LIC. NO. 54947	CHK:	CHK:
EMBAKMENT PROTECTION FOR BOX CULVERTS		APPROVED:	
SHEET NO. 7 OF 13 SHEETS		BRIDGE NO. 41J84	

SCALE: 1"=30'



BLANKET



SEDIMENT LOGS



RIPRAP



DRAINAGE DIRECTION

NOTE:

- EXCAVATE TO PLACE TOP OF RIP-RAP AT OR BELOW OUTLET ELEVATION

ROLLED EROSION PREVENTION, CATEGORY 20

STATION	SIDE	REMARKS	SQ. YD.
42+47-43+34	LT.	OUTLET	141
42+40-42+90	RT.	INLET	107
TOTAL =			248

*QUANTITIES MAY BE ADJUSTED BY ENGINEER IN THE FIELD

RANDOM RIPRAP CLASS III

STATION	SIDE	REMARKS	QUANTITY
42+54-42+82	RT.	INLET	48
42+56-43+07	LT.	OUTLET	96
TOTAL			144

*1.3 TONS PER CUBIC YARD

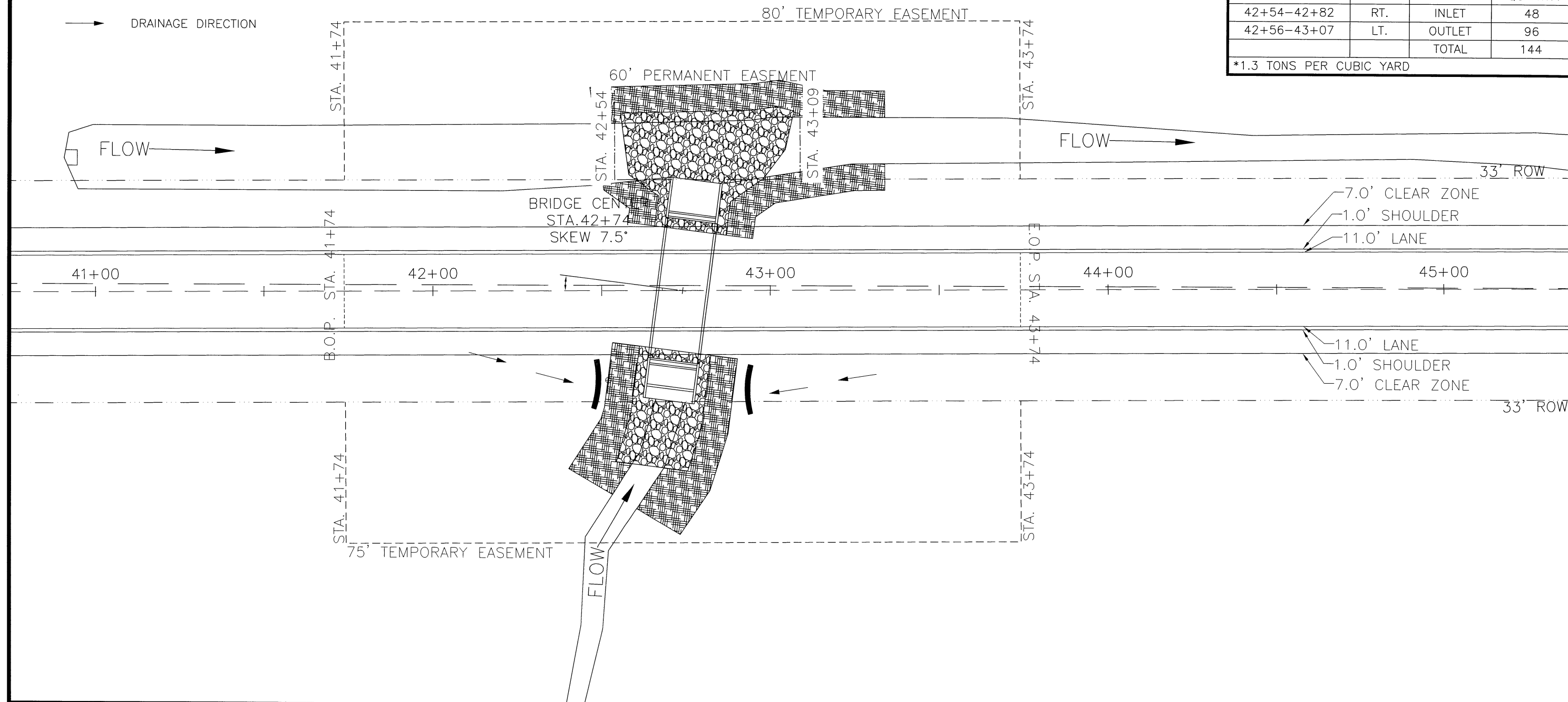

EROSION & SEDIMENT CONTROL PLAN

CERTIFIED BY *Joseph M. Wilson* LIC. NO. 54947 DATE: 11-29-22
LICENSED ENGINEER

S.A.P. NO. 041-599-069 SHEET NO. 8 OF 13

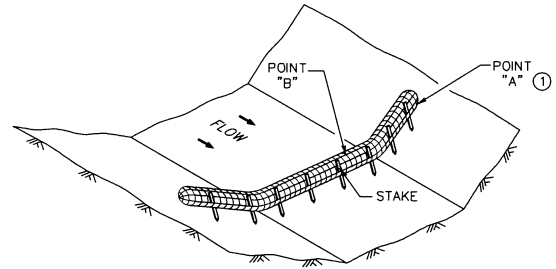

SEDIMENT CONTROL LOG TYPE WOOD FIBER, OR TYPE COMPOST ② ③

NOTES:

- SEE SPECS. 2573, 3601, 3733, 3885, 3886 & 3889.
- FOR DITCH CHECKS, PLACE SEDIMENT CONTROL LOG PERPENDICULAR TO FLOW AND IN A CRESCENT SHAPE WITH THE ENDS FACING UPSTREAM.
- APPROXIMATE SPACING BETWEEN EACH DITCH CHECK SHOULD BE DETERMINED FROM THE FOLLOWING SPACING FORMULA:
- $$\text{APPROXIMATE SPACING OF DITCH CHECKS (FT.)} = Y = \frac{\text{DITCH CHECK HEIGHT (FT)}}{\% \text{ CHANNEL SLOPE}} \times 100$$
- ① POINT "A" MUST BE A MINIMUM OF 6 INCHES HIGHER THAN POINT "B" TO ENSURE THAT WATER FLOWS OVER THE DIKE AND NOT AROUND THE ENDS.
 - ② DITCH GRADE 1.5% - 3%, MAX. FLOW VELOCITY 4.5 FT./SEC. (SEDIMENT CONTROL LOG WITH EROSION CONTROL BLANKET)
 - ③ DITCH GRADE 1.5% - 3%, MAX. FLOW VELOCITY 1.5 FT./SEC. (SEDIMENT CONTROL LOG WITHOUT EROSION CONTROL BLANKET)

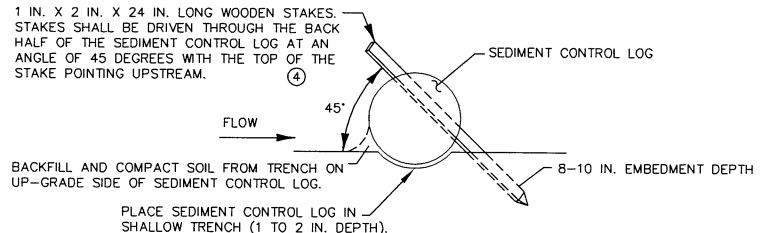

TYPES: STRAW, WOOD FIBER, OR COIR

NOTES:

- SEE SPECS. 2573, 3149, 3874, 3882, 3886, & 3897.
- ④ SPACE BETWEEN STAKES SHALL BE A MAXIMUM OF 1 FOOT FOR DITCH CHECKS OR 2 FEET FOR OTHER APPLICATIONS.
 - ⑤ PLACE STAKES AS NEEDED TO PREVENT MOVEMENT OF SEDIMENT CONTROL LOGS PLACED ON SLOPES OR AS NEEDED DUE TO OTHER FACTORS. STAKES SHALL BE INCIDENTAL.

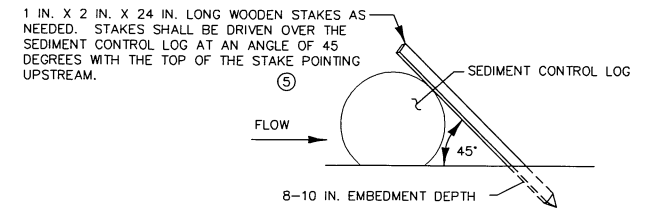

TYPES: WOOD CHIP, COMPOST, OR ROCK

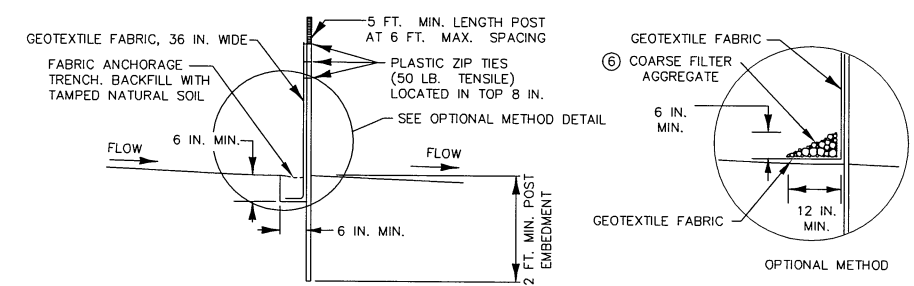

SILT FENCE TYPE HI ⑦ (HAND INSTALLED)

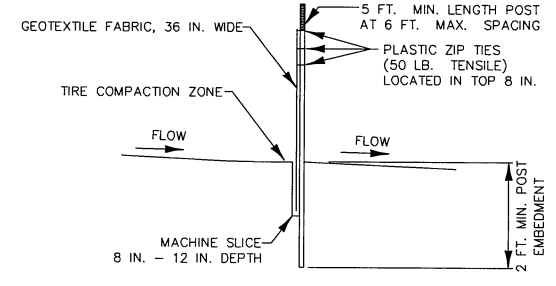

SILT FENCE TYPE MS ⑦ (MACHINE SLICED)

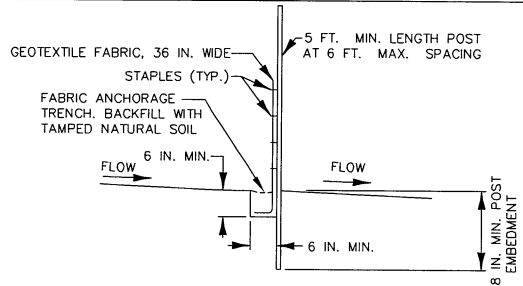

SILT FENCE TYPE PA ⑧ (PREASSEMBLED)

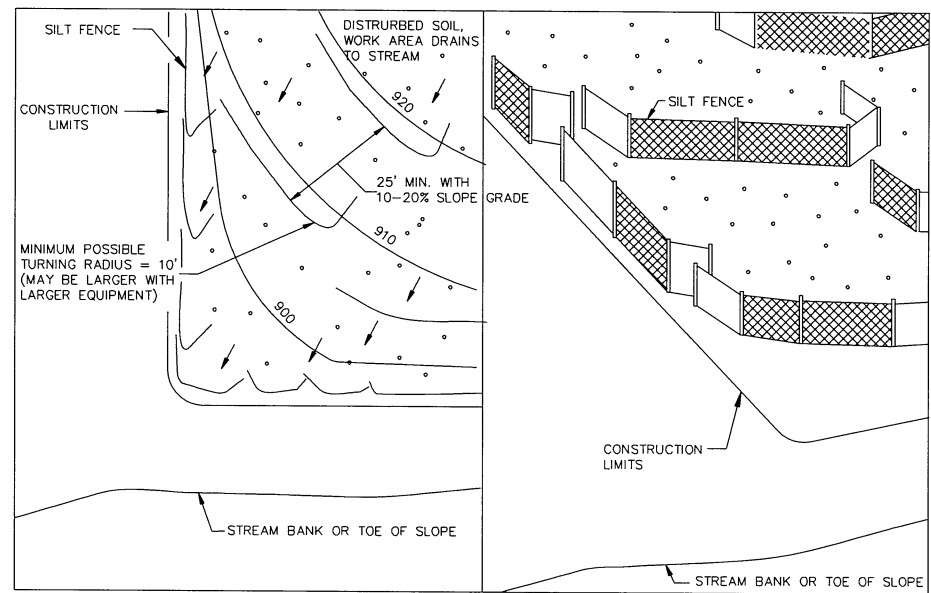

J-HOOK INSTALLATION

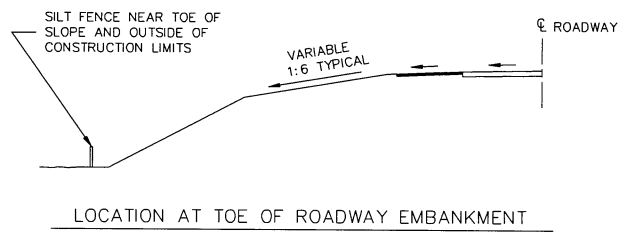

LOCATION AT TOE OF ROADWAY EMBANKMENT

NOTES:

- SEE SPECS. 2573, 3149 & 3886.
- ⑥ COARSE FILTER AGGREGATE (SPEC. 3149) SHALL BE INCIDENTAL.
 - ⑦ TO PROTECT AREAS FROM SHEET FLOW. MAXIMUM CONTRIBUTING AREA: 1 ACRE.
 - ⑧ TO PROTECT AREAS FROM SHEET FLOW. MAXIMUM CONTRIBUTING AREA: 0.25 ACRE.

SEDIMENT CONTROL DETAILS

CERTIFIED BY *Joseph M. [Signature]* LIC. NO. 54947 DATE: 11-29-22
 LICENSED ENGINEER

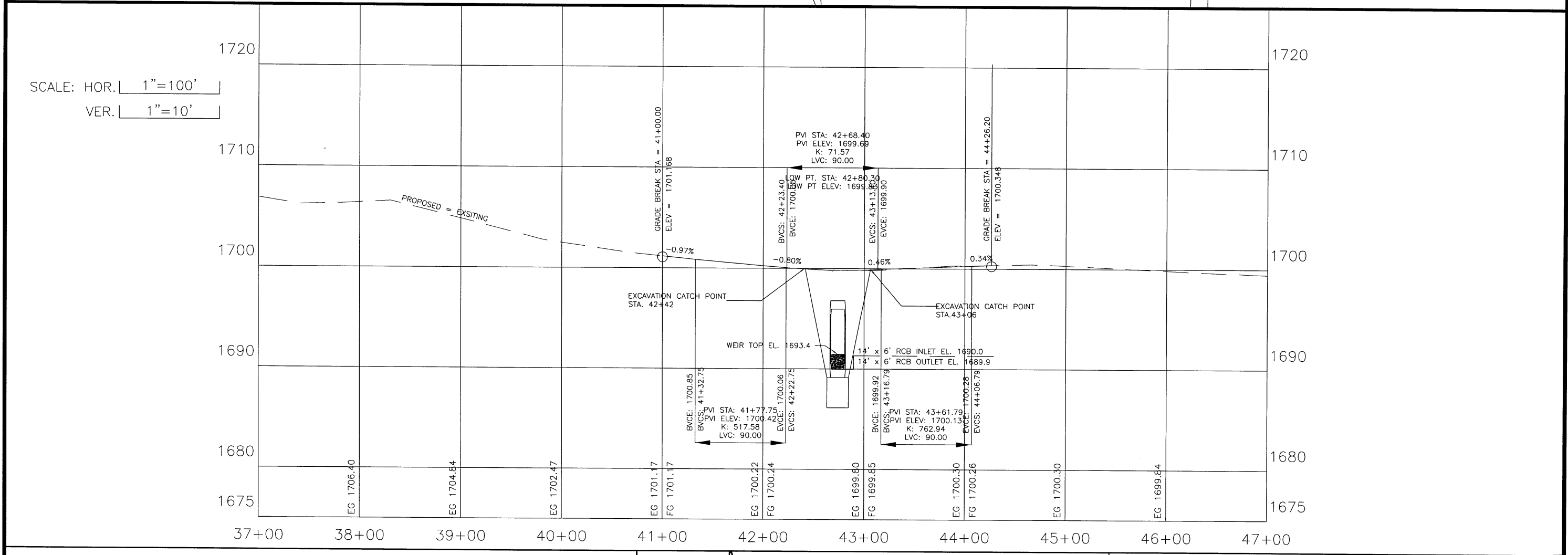
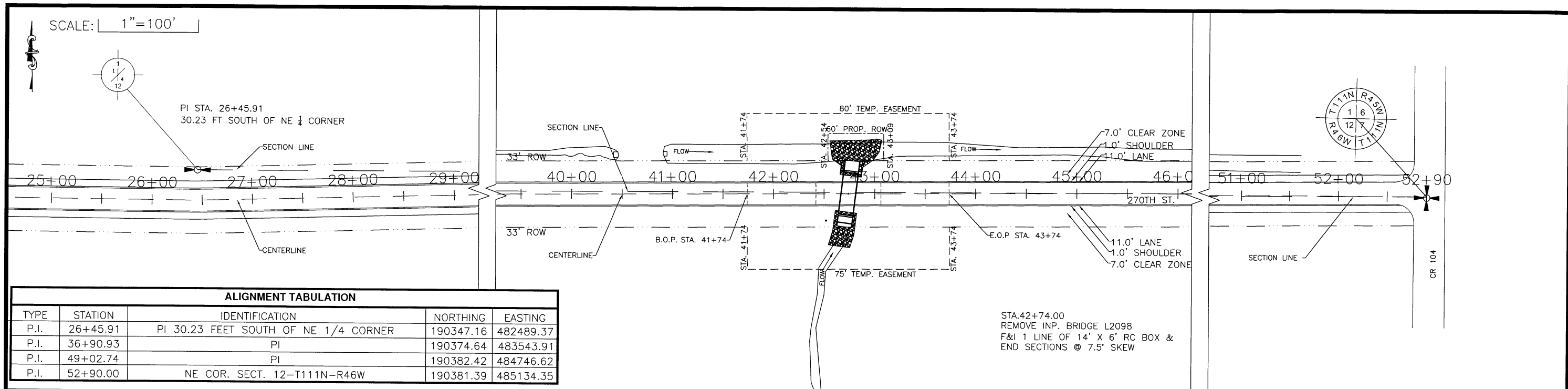

PLAN & PROFILE

CERTIFIED BY *Joseph M. Hilton* LIC. NO. 54947 DATE: 11-29-22
LICENSED ENGINEER

S.A.P. NO. 041-599-069 SHEET NO. 10 OF 13

PLAN

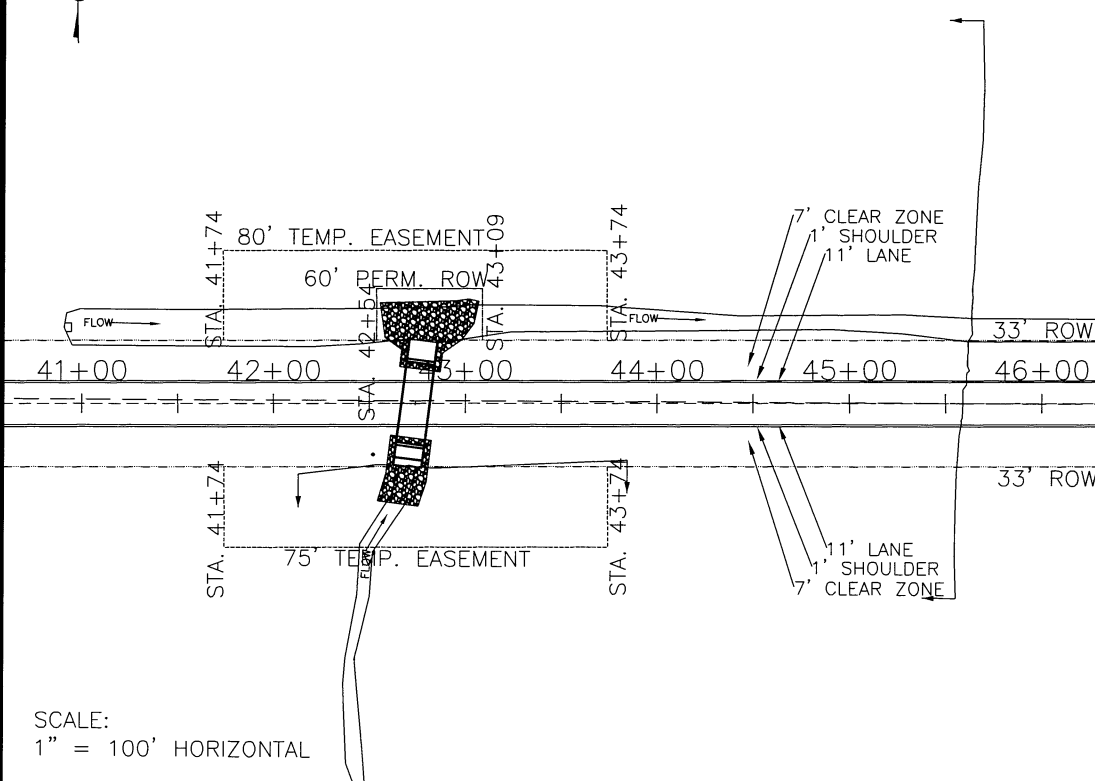

SCALE:
1" = 100' HORIZONTAL

VERTICAL PROFILE

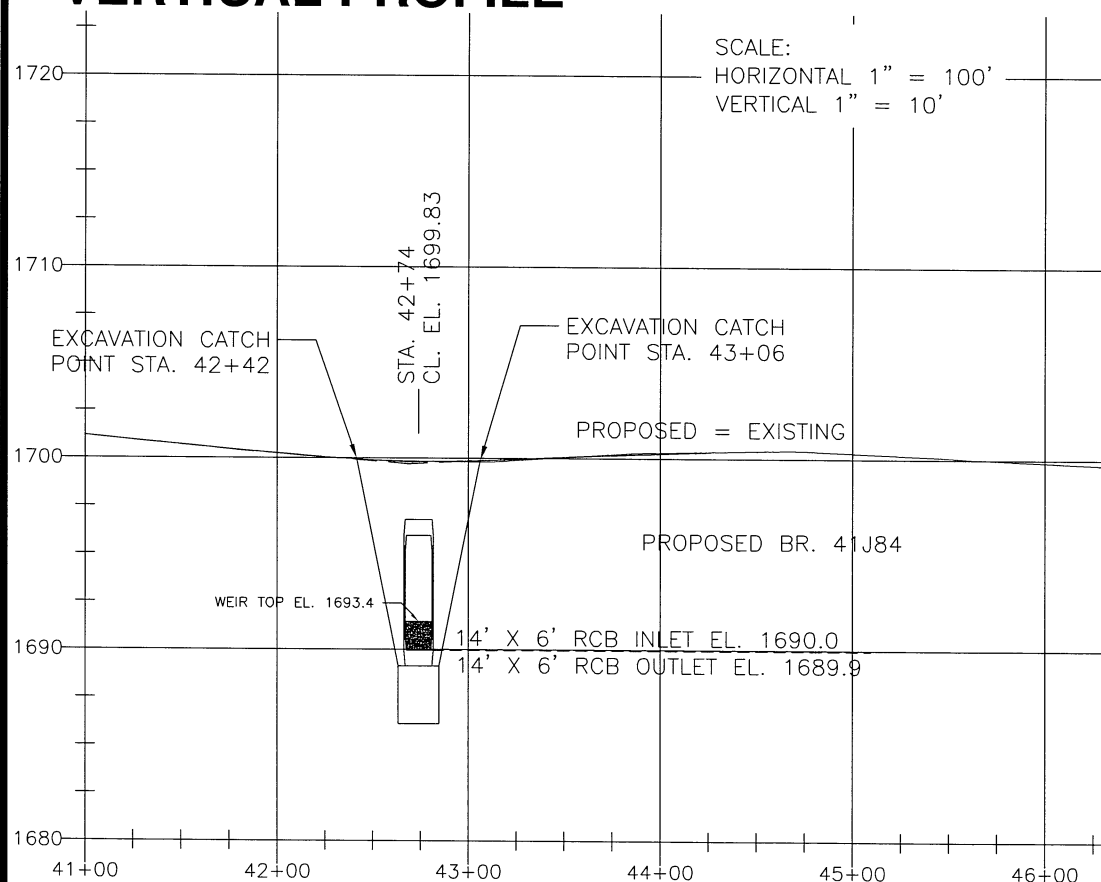

SCALE:
HORIZONTAL 1" = 100'
VERTICAL 1" = 10'

SCALE:
1" = 200' HORIZONTAL
1" = 4' VERTICAL

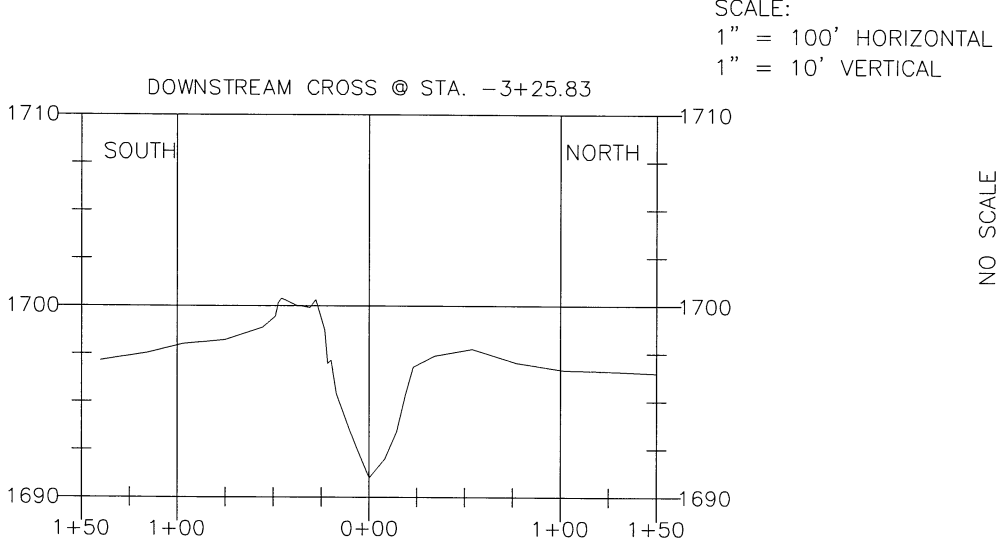
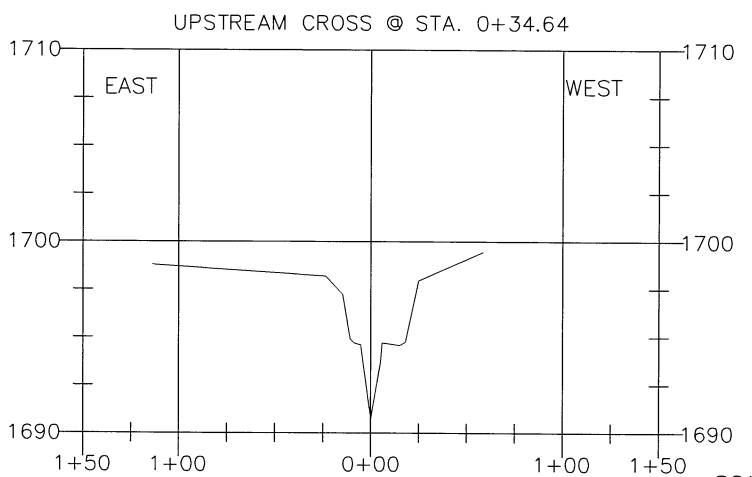
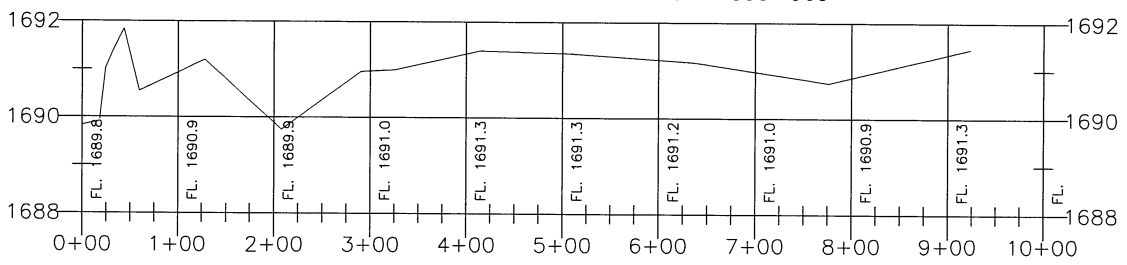
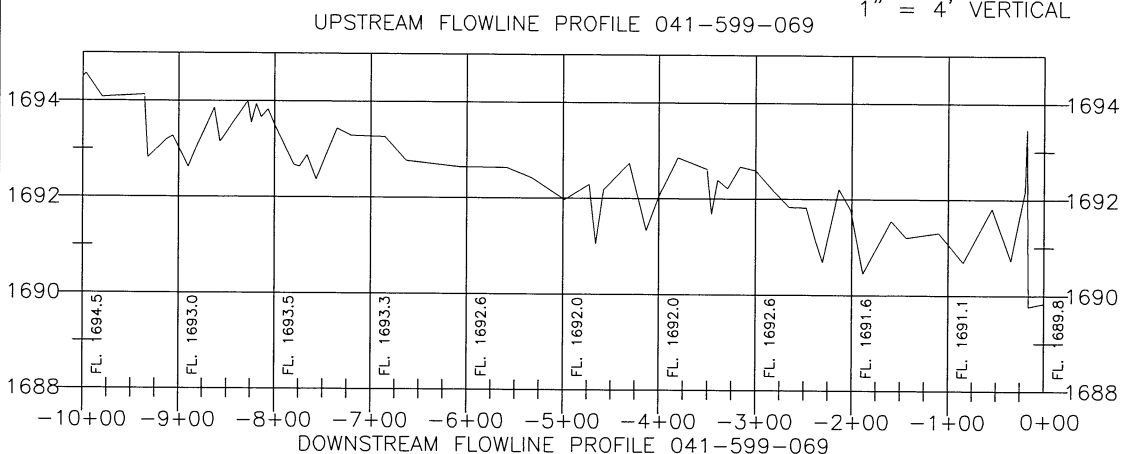

SCALE:
1" = 100' HORIZONTAL
1" = 10' VERTICAL

FEDERAL PROJ. NO.

LOCATION ENGINEER'S OBSERVATION AT BRIDGE SITE

- SPECIAL FEATURES: WATERFALLS, DAMS, FLOODS, ICE DEBRIS, ETC...
INLET OF EXISTING BRIDGE HAS A 3.7' WEIR WALL
- OTHER BRIDGES OR CULVERTS OVER THE SAME STREAM. GIVEN LOCATION, TYPE, ETC...

- APPARENT HIGH WATER ELEVATION _____ OBTAINED FROM _____
- OTHER DATA: APPROX. VELOCITY OF WATER AT TIME OF SURVEY

HYDRAULIC ENGINEER'S RECOMMENDATION

DATE: APRIL 5, 2019
 STREAM OR DITCH DESIGNATION YELLOW MEDICINE RIVER MAIN DRAINAGE AREA
 DRAINAGE AREA 18 SQ. MI.
 MAX. FLOOD ON RECORD UNK. DESIGN HEADWATER ELEV. 540 CFS
 MAX. OBSERVED HIGHWATER ELEV. UNK. DESIGN HEADWATER ELEV. 1698.0
 DESIGN MEAN VELOCITY THROUGH STRUCTURE 6.4 FPS (AVG.)
 LOW SUPERSTRUCTURE AT OR ABOVE ELEVATION 1695.95 FT
 FLOWLINE ELEVATION 1689.95 FT SKEW ANGLE 7.5°
 BASIC FLOOD (100 YR. FREQ.): 540 CFS
 BASIC HEADWATER ELEVATION: 1698.0 FT
 GREATEST/OVERTOPPING FLOOD (500 YR FREQ.) 830 CFS
 GREATEST/OVERTOPPING HEADWATER ELEVATION: 1700.2 FT

ENGINEER'S RECOMMENDATION

INSTALL 1 LINE OF 14' X 6' RC BOX CULVERT AT A 7.5° SKEW. A WEIR TO BE INCORPORATED INTO THE UPSTREAM APRON TO ACCOUNT FOR THE ELEVATION DIFFERENCE BETWEEN THE UPSTREAM AND DOWNSTREAM CHANNEL ELEVATIONS.

BRIDGE SURVEY SHEETS MADE FROM LINCOLN COUNTY HIGHWAY DEPARTMENT SURVEY
 BENCHMARK ELEVATION 1761.29
 LOCATION ANDERSON MN081, LOCATED ON C.R. 104 ON THE SOUTHEAST CORNER OF THE INTERSECTION C.R. 104 & T.H. 19

VICINITY MAP

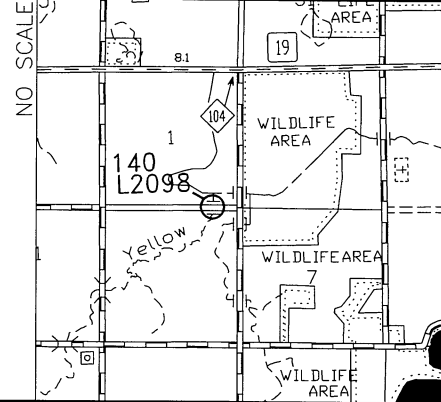

STATE OF MINNESOTA DEPARTMENT OF TRANSPORTATION

BRIDGE SURVEY

AT STATION 42+74 ON 270TH ST
 PROPOSED BRIDGE LOCATION 0.2 MILES WEST OF INTERSECTION OF C.R. 104
 SEC. 12 TWP. 111N RNG. 46W
 TOWNSHIP: SHAOKATAN
 COUNTY: LINCOLN EXISTING BRIDGE NO.: L2098
 PROPOSED BRIDGE NO. 41J84

CERTIFIED BY Joseph M. Nelson LIC. NO. 54947 DATE: 11-29-22
 LICENSED ENGINEER

STORM WATER POLLUTION PREVENTION PLAN (SWPPP)

PROJECT DESCRIPTION

S.A.P. 041-599-069 CONSISTS OF REMOVING THE EXISTING STRUCTURE (EXISTING BRIDGE L2098) OVER YELLOW MEDICINE RIVER MAIN, LOCATED APPROXIMATELY .20 MILES WEST OF C.R. 104 ON TOWNSHIP ROAD 270TH ST., AND REPLACING IT WITH 1 LINE OF 14'X6' RC BOX (NEW BRIDGE #41J84). CONSTRUCTION ACTIVITY INCLUDES REMOVAL OF THE EXISTING STRUCTURE, INSTALLING THE NEW BOX CULVERT, BACKFILLING, AND GRADING. THE TOTAL NET LENGTH OF THE PROJECT IS 200 FEET. THE RECEIVING WATER FOR STORM WATER FROM THIS PROJECT IS RIVER ID 07020004-782. YELLOW MEDICINE RIVER BRANCH IS CONSIDERED AN IMPAIRED WATER FOR ESCHERICHIA COIL, MERCURY IN FISH TISSUE, AND TURBIDITY.

PROJECT ENGINEER

THE PROJECT ENGINEER AND THE CONTRACTOR ARE RESPONSIBLE FOR THE IMPLEMENTATION OF THE SWPPP AND THE INSTALLATION, INSPECTION, AND MAINTENANCE OF THE EROSION PREVENTION AND SEDIMENT CONTROL BMP'S BEFORE AND DURING CONSTRUCTION.

TIMING AND BMP INSTALLATION

THE EROSION PREVENTION AND SEDIMENT CONTROL BMP'S SHALL BE INSTALLED AS NECESSARY TO MINIMIZE EROSION FROM DISTURBED SURFACES AND CAPTURE SEDIMENT ON SITE, AND SHALL MEET THE NPDES PERMIT PART IV CONSTRUCTION ACTIVITY REQUIREMENTS.

CALCULATIONS FOR STA. 41+74 TO 43+74 (BRIDGE REPLACEMENT AND GRADING)

WATER QUALITY VOLUMES
 NEW IMPERVIOUS AREA 0.165-0.165 ACRES = 0.000 ACRES = 0.000 SQ. FT.
 WATER QUALITY VOLUME 0.000 SQ. FT. * 1 IN. = 0.000 CU. FT.

SWPPP DESIGNER
 KYRA PAVEK - LINCOLN COUNTY TECHNICIAN

AMENDING THE SWPPP

THE SWPPP MUST BE AMENDED TO RECORD CHANGES OR MODIFICATIONS TO PERMIT BMP'S OR OTHER STORM WATER TREATMENT SYSTEMS AND REMOVALS OF TEMPORARY BMP'S. CHANGES TO TEMPORARY BMP'S MAY BE RECORDED ON THIS SHEET. INCLUDE A BRIEF DESCRIPTION OF THE PROBLEM, LOCATION, NATURE OF ALTERATION, AND COMMENTS. THIS RECORD IS TO BE RETAINED FOR THREE YEARS AFTER PROJECT COMPLETION.

LOCATION OF SWPPP REQUIREMENTS IN PROJECT PLAN		
DESCRIPTION	TITLE	LOCATION
SUMMARY OF PERVIOUS AND IMPERVIOUS	SWPPP	SHEET 12
DIRECTION OF FLOW	EROSION & SEDIMENT CONTROL PLAN	SHEET 8
RECEIVING SURFACE WATERS	SWPPP	SHEET 12
FINAL STABILIZATION	EROSION & SEDIMENT CONTROL PLAN	SHEET 8
DRAINAGE TABULATION	SWPPP	SHEET 12
EROSION CONTROL TABULATION	EROSION & SEDIMENT CONTROL PLAN	SHEET 8
EROSION CONTROL SHEETS	EROSION & SEDIMENT CONTROL PLAN & EROSION CONTROL DETAILS	SHEETS 8-9
SEDIMENT CONTROL DETAILS	SEDIMENT CONTROL DETAILS	SHEET 9

DATE REPORTED	STAFF (SHEET)	PLAN LOCATION (STATION)	PROJ. LOCATION	PROBLEM, SOLUTION, AND NOTES

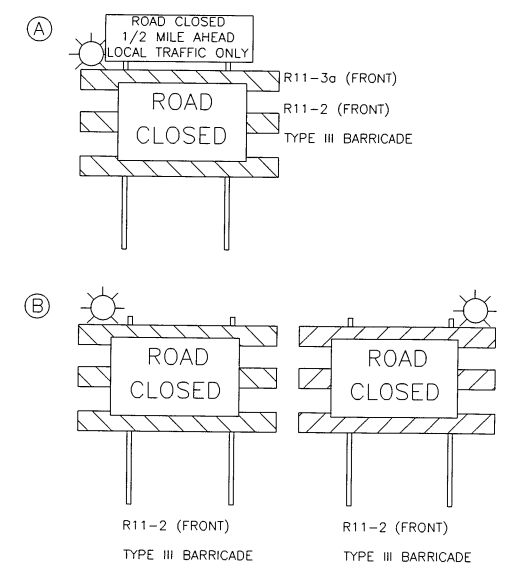

NOTE:
 CONTRACTOR SHALL INSTALL AND MAINTAIN ORANGE SAFTEY FENCE
 OR OTHER MATERIAL ACCEPTED BY THE ENGINEER AS TO
 COMPLETELY BLOCK THE ROADWAY FROM SHOULDER PI TO
 SHOULDER PI AT THE BARRICADE (B) LOCATION.

SIGN	SIGN NO.	QUANTITY	SIZE	COLOR	FLASHERS
	TYPE III BARRICADE	6	60" X 48"	ORANGE ON WHITE	6
	R11-2	6	48" X 30"	BLACK ON WHITE	
	R11-3a	2	60" X 30"	BLACK ON WHITE	

ALL TRAFFIC CONTROL DEVICES SHALL BE IN ACCORDANCE WITH THE LATEST EDITION OF THE MINNESOTA MANUAL OF UNIFORM TRAFFIC CONTROL DEVICES AND THE LATEST EDITION OF THE TEMPORARY TRAFFIC CONTROL ZONE LAYOUTS FIELD MANUAL.

ALL NECESSARY TRAFFIC CONTROL DEVICES ON THIS PROJECT SHALL BE THE RESPONSIBILITY OF THE CONTRACTOR.

TRAFFIC CONTROL

CERTIFIED BY *Joseph M. [Signature]* LIC. NO. 54947 DATE: 11-29-22
 LICENSED ENGINEER